

# Automatic Challan System with Health Monitoring using PRS

Prof. Nitin S. Khachane<sup>1</sup>, Aboli Deshmukh<sup>2</sup>, Dipali Sonwane<sup>2</sup>, Purva Kale<sup>2</sup>, Pratima Shiradkar<sup>2</sup>

<sup>1</sup>Asst. professor, Department of Computer Engineering, PRMIT&R, MS 444 701, India

<sup>2</sup>Students, Department of Computer Engineering, PRMIT&R, MS 444 701, India

**Abstract:-** As there is a increase in the population the number of vehicles is increasing in number. It is very monotonous to keep all the vehicle related documents along with us and also the checking and verification of these documents is difficult and tedious for traffic police and also maintaining the challan regarding the vehicles. Therefore, the proposal of this system is in the favor that the traffic police will be able to generate the challan through the application linking it with the vehicle and the driver has to pay the online challan. The health monitoring is the important feature of this research which is used for the police which is using pulse rate sensor that includes the optical technology to detect the flow of blood through the finger and offers the advantages of portability over tape-based recording system. The use of Discrete Fourier Transform to analyze the ECG signal in order to measure heart rate is the important feature of this research. The use of this application is to provide services to driver (user) and traffic police.

**Keywords:-** QR-code, Camera, Application Program, Android, Pay Challan, SMS-Gateway, Fingertip Sensor, Heart Rate Monitor(HRM)

## I. INTRODUCTION

In day to day life, there is a drastic increase in population. Now-a-days most of the people are using vehicles. Due to this work of traffic police has increased. RTO management has a lot of work associated to the registration of vehicle and also related documents. Regularly, we observe that people have to wait and show the documents of their vehicles to the traffic police. This consumes a lot of time of the driver and also the police who has to check the documents and return it again. Sometimes the driver forgets to carry the vehicles related documents due to some reason and therefore has to pay fine. The aim of the proposed system is to reduce the work of traffic police and also driver has no need to carry vehicles documents along. If any vehicle is stolen, we can easily detect the vehicle using RFID. Quick Response codes, commonly abbreviated as QR

codes, used as an a1- D bar code, a QR code is nothing but a 2- D matrix code. The arrangement of its dark and light elements columns and rows conveys the information. Here QR code is used for license identification and to retrieve the PUC, RC book, and insurance we use vehicle number. The number of heart beats per unit of time is termed as Heart Rate, typically expressed as beats per minute (bpm). To assist in the diagnosis and tracking of medical conditions the medical professionals use the measurement of the heart rate. As the body's need to inhale oxygen and exhale carbon dioxide changes during exercise or sleep the heart rate can vary. The heart rate rises gradually during exercises and slowly returns to normal after exercise. The pulse rate which the returns to normal is the indication to the fitness of the person.

## II. LITERATURE REVIEW

Sharief, Liena, and Samah [1] It has presented the design and development of a low-cost HRM device. The device is ergonomic, durable, cost effective and portable. Mr. Nilesh R. Patil and Prof. Rajesh Dharmik [3] The security architecture for the cloud service provider is designed. They reported that the cloud model provides more security because only the authenticated person can access the information from the cloud. Lokesh and Prajakta [4] show the strength of QR-code, To manage all the process Administrator was provided for authentication purpose for the handling of all the database of E-RTO Dr. G. M. Bhandri, Rakhi, Anjali, and Amol [6] An authorized user should be allotted a user name and password through which they can access detailed information from the site excluding access to the general information.

## III. METHODOLOGY

To propose and experimentally evaluate an automated system, called Challan System and vehicle verification is therefore the aim of the present work. In this, we create an application for traffic police on duty.

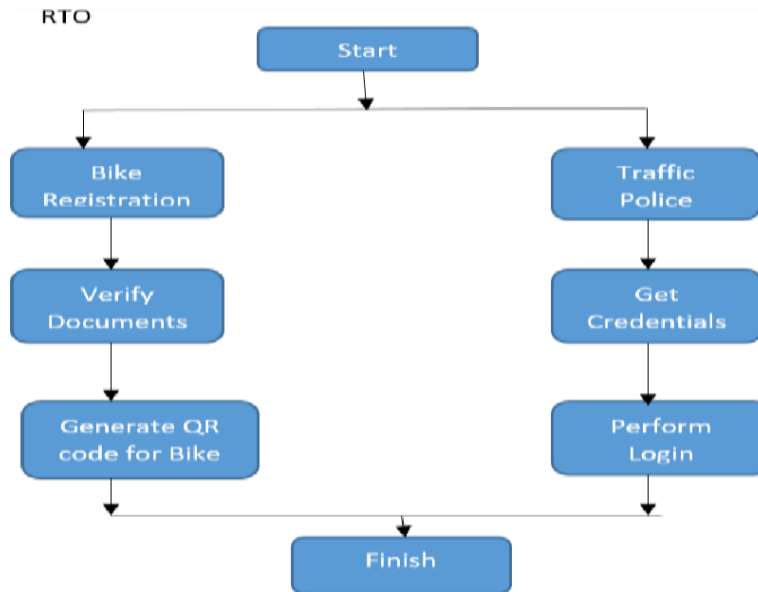

Fig 1:- RTO Flow Diagram

A. The Working of the System:

The application has two parts and from which the one is restricted for the use of the traffic police and the government authorities. On login the officer gets a menu showing two options.

- **Alert:** The alerts will have sub- options where officer alerts other officers and police department about any theft of vehicle or crime committed by a vehicle.
- **Vehicle check:** The vehicle check contains further sub-options to check owner details, an issue challan.
- **Check Owner Details:** Here the officer can check the details of the vehicle, its documents as well as its owner.
- **Issue challan:** In this the officer checks the check-box against the rule broken. Then select the ‘submit and send to owner’ button which will generate a receipt which will

be received by the owner by the means of the owner’s registered mobile number.

B. System Hardware:

The proposed HRM device comprises of the following features:

- To detect the modulation caused by the electrical or physical changes in the heart movements the system provides the optical mechanism.
- The system shows the output of therefore calculated heartbeat on the LCD screen. Also,for entering user data and configuration data the display is used.

Fig.2 shows the overview diagram of the proposed device.

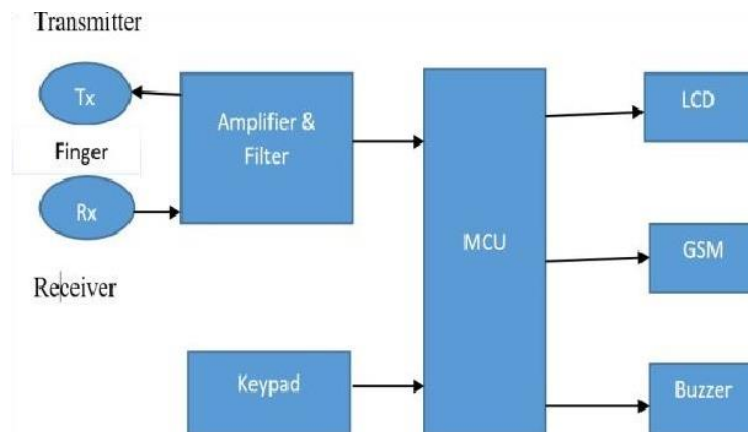

Fig 2:- Block diagram of the HRM system.

C. Fingertip Sensor

The sensor consists an IR detector which acts as the receiver and the also consists the IR light emitting diode transmitter. That IR light that passes through the tissues. The amount of light incident on the IR detector is modulated by the variations in the volume of blood within the finger. The implementation of Two practical configurations could be done to achieve this information. Prior to this configuration,

the placing of the finger can be done between the transmitter and the receiver . In the design the finger would function as a reflector of the incident light by placing the IR transmitter and receiver in the same plane. The reflected signal is thus monitored by the IR receiver. There is reduction in the interference from the mains 50Hz noise due to the use of IR filter of the photo transistor.

#### IV. CONCLUSION

In this paper, the low designed application with the heartbeat monitoring kit has been presented. The application is used for the smooth and reliable services on the road. It reduces workload of the traffic police and driver by automatic challan generation and checking of all the relevant documents. The kit proposed in the system can be used at any environmental conditions. It can also be used by any individual to check their heartbeat rate. This would be very useful for the traffic police who work in any climatic conditions for the safety of the citizens and would take care of the ones who take care of others irrespective of their own. The HRM device which cheap and easy to use would end up to be the most effective way to take care of traffic police office.

#### REFERENCES

- [1] Sharief F. Babiker, Liena Elrayah Abdel-Khair, and Samah M. Elbasheer “Microcontroller Based Heart Rate Monitor using Fingertip Sensors” University of Khartoum Engineering Journal (UOFKEJ), Vol.1 Issue 2pp.47- 51(October2011)
- [2] B.G. Ahn, Y. H. Noh, and D.U. Jeong, Smart chair based on multi heart rate detection system. In 2015 IEEE SENSORS, pages 1-4, Nov 2015.
- [3] Mr. Nilesh R. Patil, Prof. Rajesh Dharmik, Secured Cloud Architecture for Cloud Service Provider IEEE (WCFFTR16), 2016.
- [4] Lokesh S. Khedekar, Prajakta S. Kale, “Strength QR-Code over Design and Implementation of verification system”. IEEE (ICCSP), 2016. pp 21902193.
- [5] S. H. Almotiri, M.A. Khan, and M. A. Alghamdi, Mobile health (m-health) system in the context of iot, In2016 IEEE 4<sup>th</sup> International Conference on Future Internet of Things and Cloud Workshops (FiCloud), pages 39-42, Aug 2016.
- [6] Dr. G. M. Bhandari, Rakhi Vishwakar Anjali Jadhav, Amol Mutyelu, Amol Bhosale, “Smart System for Vehicle User and Traffic Controller”, International Engineering Research Journal (IERJ), Volume 2 Issue 9 Page 34913493, ISSN 2395-1621, April 2017.