

# Design and Fabrication of a Solar Operated Lawnmower

ADUBIKA OLUWATOBI AKINYEMI AND ADEBAYO SOLOMON DAMILARE

## DEDICATION

This project report is dedicated to all Mighty God and all Mechanical Engineers.

## ABSTRACT

In recent times, the entire world has been in consistent search of cleaner and safer ways of generating and producing energy. Due to continuous industrialization in different parts of the world, there has been a huge deterioration in the natural state of the environment. This is reflective in different areas and the most prominent has to be Climate change. This paper therefore focuses on the exploitation of the abundant solar energy to gotten from the sun to drive a lawn mower. The designed solar powered lawn mower comprises of electric motor, a charge controller, battery (12V, 40ah), Solar Panel (100W), rotational blade and a control switch. The entire operation frame work is achieved using the electric motor which is able to provide the necessary torque needed for the rotation of the blade which is mounted to the shaft of the motor. The solar powered lawn mower is operated by a switch on the board which closes the circuit and allows current flow to the motor and ultimately, causing the actuation of the blade. The battery took about 5hours to charge and 50 minutes of operation time before completely discharging. However, under a very sunny condition battery charges and operates simultaneously, taking a longer time to discharge. Finally, the performance evaluation of the battery was carried out with the machine and it was found to have a theoretical efficiency of 85%

## CHAPTER ONE

### INTRODUCTION

#### 1.1 CONCEPT OF SOLAR LAWN MOWER

The use of solar power as an alternative source of energy has been in existence long before now but has not had diverse application methods due to other frequently used sources of energy. Solar energy involves the process of harnessing radiant light and heat from the sun using a range of ever evolving technologies such as solar thermal energy and photovoltaics. These technologies are broadly characterized as either passive solar or active solar depending on how the energy is converted to solar power. The effectiveness of these technologies have made solar energy a very important source of renewable energy and thereby giving room for new developments in its wide range application processes. In the world today, world's power consumption is taking a shift from the use of common sources of energy such as fossil fuel and wood fuels to solar energy. The change in energy consumption trend was due to the awareness of fossil fuel pollution and its contribution to global warming, and also the fact that fuel energy is non-renewable and unsustainable.

In Nigeria today, like most other developing countries, fossil fuel has been a basic source of non-renewable energy. Pending the fact that we import fuel there is always a tendency of a hike in the cost of fuel as a result of the country economical instability.

Lawn maintenance is the art and vocation of keeping a lawn healthy, clean, safe and attractive, typically in a garden, park, institutional setting or estate. Man is constantly trying to adapt to his environment by creating a habitat suitable for his survival.



*Fig 1.1 Concept of the first lawn mower*

The first lawn mower was invented by Edwin Budding in 1830 in Thrupp, Gloucestershire, England. His mower was designed primarily to cut the grass on sports grounds and extensive gardens as superior to scythe. The scythe was the first device ever used to cut grass to a desirable height. It has a simple design, containing a long wooden handle with a curved blade attached perpendicularly to the end. Until the 19th century, the scythe was the only option for cutting grass, which proved to be a long tedious process. Budding's idea of a lawn mower came after watching a machine in a local cloth mill which used a cutting cylinder mounted on a bench to trim clothes for a smooth finish after weaving (Ramalingeswara, 2015). Budding assumed that similar concept could be used to cut grass if the mechanism is mounted on a wheel frame to enable the blades rotate close to the lawns surface. These early machines were made of cast iron and featured a large rear roller with a cutting cylinder (reel) in front. The cutting cylinder contained several blades connected in series around the cylinder (Sheikh & Ahmad, 2018). The cast iron gear wheel transmitted power from the rear roller to the cutting cylinder blade.

After the development of Buddings lawn mower, he made an agreement with John Ferrabee, a fellow English engineer. After obtaining a patent in 1830, Ferrabee had license to manufacture and sell the product. During the production of his product, he licensed other companies, allowing them to produce the mower as well. Other companies were finally able to produce their own mowers in the 1850s when the patent was terminated. Thomas Green innovated the first ever chain driven lawn mower in 1859. Since Green used chains to transmit power from the roller rather than gears, it reduced the noise of the mower. Amariah Hills was the first American to obtain a patent for a mower design and innovated the Archimedean Lawn Mower Co. in 1871 (Venkatesh, 2015). In 1870, Elwood McGuire of Richmond, Indiana designed a human-pushed lawn mower, which had a very lightweight and became a commercial success (Venkatesh, 2015). This design made it possible for the operator to easily move the mower rather than exerting as much energy as the older push mower designs required. Although a lighter push mower had been designed, mowing grass proved to be an inconvenient and long task. Therefore, a non-man powered mower was desired. Resorting back to horse drawn mowers was not an option in order to keep a pristine lawn and resulted in the next big innovation of motorized mowers. In the 1890s, steam powered engines were commonly used, but the time it took to fire it up became even more of an issue which created the desire for an engine that utilizes a different source of energy. In 1900, Ransomes, Sims, and Jefferies produced one of the best ever English machines, the first internal combustion gasoline engines available in chain or gear driven models. In 1919, Colonel Edwin George helped the United States in manufacturing gasoline powered mowers. Although this engine powered mowers were available, they were rarely used in households due to the economic problems of the time. In the 1920s and 1930s the electric powered mower, along with rotary cutting, were created but did not become popular until considerably later. Throughout the 1940s the only innovations were developing

smaller, lighter weight designs along with more powerful engines. In the 1960s, the designs were now being produced in plastic materials to further reduce the weight and cost.



*Fig 1.2: Modern gasoline powered lawn mower*

A lawn mower is a machine that uses single or multiple rotational blades to cut a grass surface to a uniform level. The mower is easy to operate and consists of a rotating blade and roller. The blade removes the extra grass growth on the lawn and the roller gives minimal pressure to the top surface of the lawn. The blades may be powered either by pushing the mower forward to operate the mechanical blades, or by an electric motor, by solar power or by a small internal combustion engine to spin the blades. Mowers employing a blade that rotates about a vertical axis are known as cutters, while those employing a blade assembly that rotates about a horizontal axis are known as cylinder reels. Many different designs have been produced for their various purposes. The smallest types which are pushed by man, are suitable for small residential lawns and gardens, while more complex mowers are suitable for large lawns, and the largest multi-gang mowers which are moved by tractors are used for large expanses of grass such as golf courses and municipal parks.

## **1.2 BACKGROUND OF THE STUDY**

A lawn mower is a grounds keeping device that makes use of one or more rotating blades to cut a grass surface to an even height. There are various ways used to power a lawn mower, but the use of solar energy as a source of energy to operate a lawn mower is the main focus of this project.

The solar powered lawn mower involves the use of solar energy to charge a direct current battery which supplies the current stored to the motor which in turn enables rotation of the blade for mowing. The solar panel receives energy from the sun, when the sun shines, the solar panel or photo voltaic cell will generate or produce voltage, the energy received from the sun goes into the charge controller. The charge controller is connected in between the panel and the battery. The main function of the charge controller is to monitor and control the flow of current and charge the battery. The charge controller will stop the current flow from the solar panel if the battery voltage exceeds a pre-set level and also stop current flow if the battery voltage drops below a pre-set level.

### **1.3 STATEMENT OF PROBLEM**

In the world today where technology is merging with environmental awareness, most people are looking for ways to contribute to the relief of their own carbon foot prints (Bidgar & Vickey, 2017).

Pollution is manmade, which can be seen in the day to day activities of man. In this part of the world, the most common types of lawn mowers are powered by gasoline engines which are hazardous to the environment thereby leading to global warming and depletion of the ozone layer.

Gasoline powered mowers create noise due to the loud engine noise, and air pollution due to the combustion in the engine. Thus, gasoline powered lawn mower contributes to both air and noise pollution. Hence, alternatives to the use of non-renewable energy and polluting fossil fuels needs to be taken into consideration.

### **1.4 JUSTIFICATION**

The solar powered lawn mower is set to eliminate both noise and environmental pollution to the barest minimum. The design can be seen as an alternate option to popular and environmentally hazardous gas powered lawn mower (Kumar & Kantiprashanth). Solar lawn mower is advantageous over gasoline powered mowers because it eliminates environmental pollution which is responsible for the emission of gases that results to global warming on the earth surface. Also, with the rate at which petroleum products are increasing day by day, the use of solar energy can be seen as a reasonable practice to the use of renewable energy sources to operate lawn mowers by eliminating the use of gasoline fuels which gasoline engines solely depends on.

## **1.5 AIM AND OBJECTIVES**

The aim and objective of this project is to design and fabricate a lawn mower which would be powered by solar energy in addition to the common gasoline engine.

The specific objectives are as follows:

- i. To study the design parameter of a solar lawn mower.
- ii. Fabrication of the solar lawn mower.
- iii. Testing of the solar lawn mower
- iv. To analyze the solar lawn mower and compare its performance with gasoline operated mowers.

## **CHAPTER TWO**

### **LITERATURE REVIEW**

#### **2.1 RESEARCH ON PREVIOUS WORK DONE**

This chapter gives an extensive review on works and study related to this project, emphasizing on different designs, analysis, areas of application and safety aspects of view. Below is a description containing related publications with the author.

In the study of D. Satwik et al design and fabrication of a lever operated solar lawn mower, the main objective was to cut grass at different heights. The proposed lawn mower had a spur gear displacement mechanism in which the rotor blade height can be adjusted by using the lever attached to it and that can proportionally change the height of the grass cut of the lawn and required grass cut can be achieved and this process of adjustment will be completed in less than 20 seconds. The components used in machine fabrication include; DC motor, battery, solar panel, spur gears, wheels, ultrasonic sensor, Arduino board and a rotor blade.

In this process, an electric brushless motor is taken to drive the rotor blade and solar energy is used to drive the motor. The batteries perform charging and discharging action between the solar panel and the motor. The actual mechanism lies between the rotor and the motor using spur gears for the power transformation. The motor runs 45min continuously until the batteries are depleted. The batteries require 23 hours to recharge completely, 10watt solar panel is used and it takes 4 days considering 6 hours direct sunlight per day to charge complete two batteries. The arduino board is an open-source computer software program used to control the speed of the motor manually. The corresponding required program is written and dumped into board. In front of the machine is an ultrasonic sensor that provides signal to prevent collision between the machine and obstacles during the cutting operation. The sensor provides signal to the arduino board before the time of collision (below 30cm from the obstacle). Buzzer receives a signal from the board and produces alarm that prevents the collision. Spur gears were used to transmit power between motor and the rotor. Contact stresses acting on the teeth of their respective spur gears were calculated theoretically using Hertz and AGMA equation.

In ogiemidia et al lawn mower design, the project work was based on improving the design of a solar operated lawn mower form a locally available sources in Nigeria. It also aimed at improving the cutting efficiency when compared to the conventional fossil fuel powered lawn mower. The components used for this design include; a 12V, 35Ah battery, 100W, 7.5A solar panel, charge controller, 1HP, 62.14A D.C

motor and a stainless steel plate. In this machine operation, there are fire inlets at different points outside the mower that draws in air into the center of the blade as it revolves. The air is push down creating a high pressure rating of underneath the machine. This high pressure rating creates lift, raising the mower on inclusion of air which also allows the mower to be easily maneuvered. When the mower moves, the lawn mower blades which are attached to the revolving of the D.C motor cut the grass. The electric circuit ensures power transfer from the battery to run the D.C. motor, while the solar panel power, and continuously recharge the battery while in operation. When the power switch is on, the electrical energy from the battery powers the motor which in turn actuates the blades. The solar panel generates current to recharge the battery, thereby compensating for the battery discharge. The solar lawn mower is made up of a lawn mower deck with handle, a 24 volts DC motor two 12 volts battery and a sickle-shaped blade. A charge controller is mounted separately used for charging the batteries. The solar panel is a photovoltaic cell that generates current when light falls on its surface. Two 100 Watts solar panels connected in series are used to charge the batteries. The D.C. motor forms the heart of the machine and provided the driving force for the cutting blades. Physical properties were obtained for three blade considering their maximum and minimum von misses stress. The concepts examined were for a tapered shaped blade, for a flat blade design and for a sickle like shaped blade. After the design analysis, concept three which involved the use of a sickle like shaped blade was selected for the lawn mower design and formed the basis for all the calculations considered.

Nagarajan et al designed and fabricated a lawn mower using a helix shaped blade. The innovation concept was to fabricate a grass cutting machine for use in an agricultural field and also to design the grass cutter without any power source so as to reduce the power consumption. The wheel rotation is achieved by human power as the machine is being pushed by the operator. The components used for the fabrication includes; a wheel, gear arrangement, roller, bearing, and base frame. The spiral lawn mower made use of multiple cutting, blade which is connected to the bevel gear is slightly raised along its rear edge to create draft that lifts the cutting blades before its cutting operation. The rotation of the cutting blade is done below the gear arrangement. As the gear arrangement rotates the reel mover tends to cut the plants or crops. The reel consists of several helix shaped blades mounted to a rotating shaft. The cutting blade used in this design is a low lift blade which is used for low speed, therefore a straight bevel gear was used due to its simplistic design and low speed. The performance of the machine was evaluated through a field test. A land predominantly covered with carpet grass was mapped out into plots of 4mx2m. Seven of these plots were selected by randomization process and mowed.



In the study of Thomas R. McCoy's solar powered golf kart, he made use of a combination of solar cells connected in an array and arranged in parallel or series connection so that a desired amount of current and voltage could be drawn. It was observed in the project study that the maximum amount of current without increasing voltage across the terminal was obtained by arranging the group of cells in the parallel connection. The array was divided into groups that included three-four cells in each. This arrangement was used mainly to charge the battery in a quick manner and this rapid charging was because of the diode which was responsible for electrical separation and that prevented the current to flow from battery to the solar cells. Every group of the solar panels had its own diode. This diode separated each group from other group of solar panels.

In the study of Anthony R. Paytas solar powered mower, the machine was designed to be operated by the electric motor. The lawnmower made use of batteries which were either charged by electric power source or by solar energy by exposing it to the sunlight insolation. In the design, the pairs of solar panels connected by the ridge of the panels was raised above the electric motor. The solar panels consisted of multiple solar cells that produced the required voltage and current. The voltage regulator at the charging outlet was connected to control current flow with respective battery. Voltage regulator was required to maintain the safe charging as additional voltage or current could be drawn from the solar cell. The electric clutch was used as electric brake which provided the opposite polarity when the safety bar was released.

In the study of Delbert R. Lucas and Ryan J. Lucas, they developed a hybrid electric lawnmower which could be operated by either direct current (DC) or alternating current (AC) power supply. A 60 volts DC supply was provided from the battery pack to the motor with a hybrid AC/DC controller which acted as step down controller or power inverter. The full bridge rectifier was used to rectify the current from AC to DC. The mower could be run in two modes such as conserve and boost mode. An additional 6volts battery was provided to hybrid AC/DC controller that increased the speed of blade motor when switched to boost mode. Furthermore, when the mower was switched to the conserve mode, the battery life was prolonged.

In the study of Ronald Thomas and Donald H. Smiths combined A.C./DC electric lawn mower, a lawn mower was designed which had both AC and DC motors. Both motors were connected by gear and clutch arrangement which could be operated together or separately. When AC motor was powered, DC was permitted to the free wheel by the clutch assembly mechanism. When the grass was dense, both the AC and DC motors were powered. Both AC and DC motors drove the gear through their association with the clutch assembly. In the design, three gears were used which were arranged in the way that they were always in the

contact with one another and the driven clutch plates were in the motion all the times. AC and DC motor were mounted adjacent to each other.

In the invention of Milshtein et al, a solar electric powered lawnmower was designed which was controlled electronically to minimize the energy consumption. Change of grass density or any other change of a load to the blade was sensed by a controller and was fed-back to the circuitry. Clean energy, low noise, no pollution, no energy cost, safe operation and low maintenance was added as benefit to the prototype to reduce its cost. Lawnmower was operated by set of batteries and solar panels. The direction of the blade could be changed so that mower could throw grass in different direction. The DC motor was selected to provide maximum efficiency of 81%-84% at the low possible current. Batteries were selected to provide high energy density (30 W- hour/kg). In this design, conventional solar cells were used with the efficiency of 14%. Solar cells were able to produce 175 watts under the normal sun condition. The machine required 24 volt and 10 ampere of current where solar cells were able to produce only 6 ampere of current.

In the study of Stephen R. Wassell, a solar powered lawn mower was designed which contained an electric motor, a rechargeable battery and photovoltaic cells panel that was attached on the handle of the lawn mower. A solar powered lawnmower was compared and studied with the gasoline powered lawnmowers from the effectiveness point of view. Both the mowers were compared and concluded that the solar powered mowers were more efficient, noiseless and had minimum energy cost. As it was solar powered, no air pollution was caused as gasoline mowers produced a lot of noise and affected the environment.

Shukitis et al, researched the methodology which solved the problem while lifting and lowering the mower deck. There was a problem with the force used to 'quick lift' of the deck. In this design, a solution was given which reduced a force of 22 pounds for lifting and lowering and for 'quick lifting', a lever system was used, that enabled the mower to lift till the maximum height.

In the study of Tony Atkins optimum blade configurations for the cutting of soft solids, the relation between the slice (blade that cuts in one rotation of the rotor) and push (the forward travel) was analyzed. It was discussed that, if the slice to push ratio was more, then the amount of grass cut was more and when the knife or blade was sharp, then more was the cutting action. In the study, the blades were arranged on helices around the cylinder and slice to push ratio was determined by the helix angle. It was also investigated that the design and ergonomics of different blades that were used in meat cutting, cylinder lawnmowers, and scythes greatly reduced the force required to cut the grass.

In the study of Johnson Alexander John's lawn mower cutting blade design, it was reviewed that in order to produce a mechanical energy, a direct current motor was used that consumed electrical energy as its input. The energy was produced due to the interaction of current carrying conductors and magnetic fields. Current or voltage was given as the input to the direct current motor and torque was the output. Self-initiated precise exchange force was utilized by the motor to control spin-waves. Sudden magnetic forces which were precisely located as well as directed were produced by the motor using the phenomena of self-initiated nonlinear magnetism.

In the study of Jean-Paul Lalonde's cutting and mulching lawn mower blades, the blade assembly for lawn mower which produced efficient mulching of the grass was reviewed. The assembly was adapted to produce self-cleaning inside the shroud housing of the mower and the internal surface of the same housing. The grass was finely mulched and blown downward outwardly of the shroud housing of the lawn mower and kept the latter clean. The grass cuttings were blown downward and it avoided the raking and reduced the need for a lateral outlet in the shroud housing. It also reduced the risks of injuries caused by obstacles which were flung outward, such as rocks, sticks, or by engagement of foot in the path of the rotating blade.

In the study of Wassell, a solar powered lawn mower was designed which contained an electric motor, a rechargeable battery and photovoltaic cells panel that was attached on the handle of the lawn mower. A solar powered lawnmower was compared and studied with the gasoline powered lawnmowers from the effectiveness point of view. Both the mowers were compared and concluded that the solar powered mowers were more efficient, noiseless and had minimum energy cost. As it was solar powered, no air pollution was caused as gasoline mowers produced a lot of noise and affected the environment.

In the study of Willsie, a lawnmower blade was designed that had improved blade bar which was flat and also slight twist was provided. A pivotal cutter discs was fitted on each end of the blade. Each end of the blade was fitted with blower elements which blew the grass. The design provided maximum throwing of cut grass from the housing of the mower during the blade rotation. To direct the cut grass into outward direction of the cutter discs, the blower elements were extended above the ends of the cutter discs. It facilitated the expulsion of the grass clipping beneath the lawnmower housing.

Considering, the previous work done by others in line with this project, the methodology used in carrying out this project differs from the various methods used in the above research work. In the design and construction of this project work, the proposed lawn mower is aimed at improving field cutting efficiency when compared with the conventional fossil-fuel powered lawn mower.

## **CHAPTER THREE**

### **METHODOLOGY**

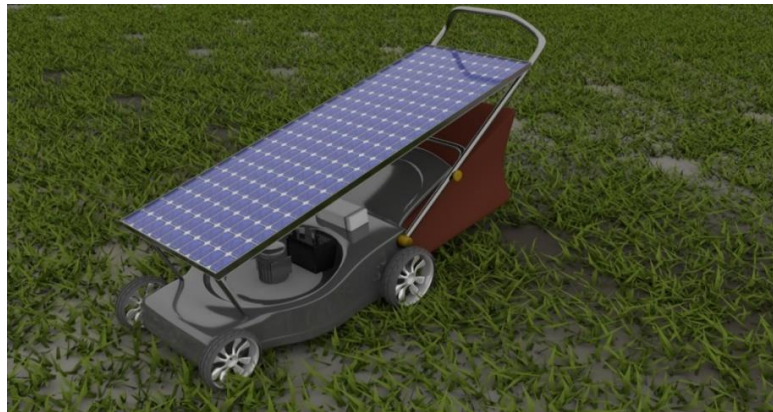
#### **3.1 DESIGN CONSIDERATION**

Several design factors should be taken into account for the economical and efficient development of a solar lawn mower. These are considerations that should be put in place during the fabrication process so as to ensure optimal productivity of the machine. Listed below are the design consideration:

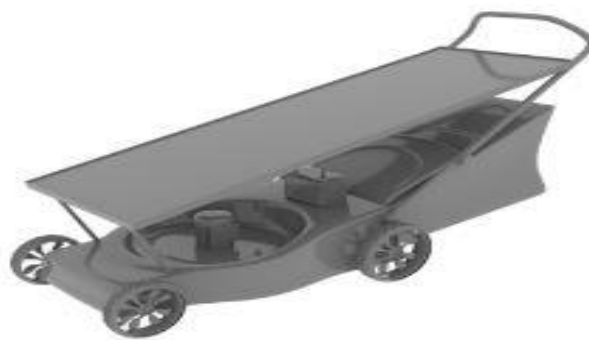
- i. The blade geometry and shape.
- ii. Materials consideration of the blade.
- iii. Ther.p.m consideration.
- iv. The deck size.
- v. The power rating of the solar panel.

Considering the design for the proposed lawn mower, the blade to be used is a flat shaped blade. They are generally referred to as standard blades engineered to provide enough lift to move the grass out of the mower deck area. Other blade shapes like tapered blade and sickle bar blade can also be used for the mower, but flat blade is preferred for this project because of its mass which is suitable considering the size and weight of the machine and speed of the motor. Tapered and sickle bar blades have higher cutting pressure but relatively low mass. The shaft rotating the blade has a high mass so the blade has to have a relative high mass to prevent the blade from wobbling. The material to be used for the desired flat blade is mild steel. Mild steel has strength and weight that can transmit the same speed as that of the motor which makes it suitable considering the size of the deck and shaft rotating the blade. Stainless steel and angle bar iron can also be used for the blade construction due to their durability and long life span. But mild steel is preferred mainly because of strength and its high resistance to corrosion.

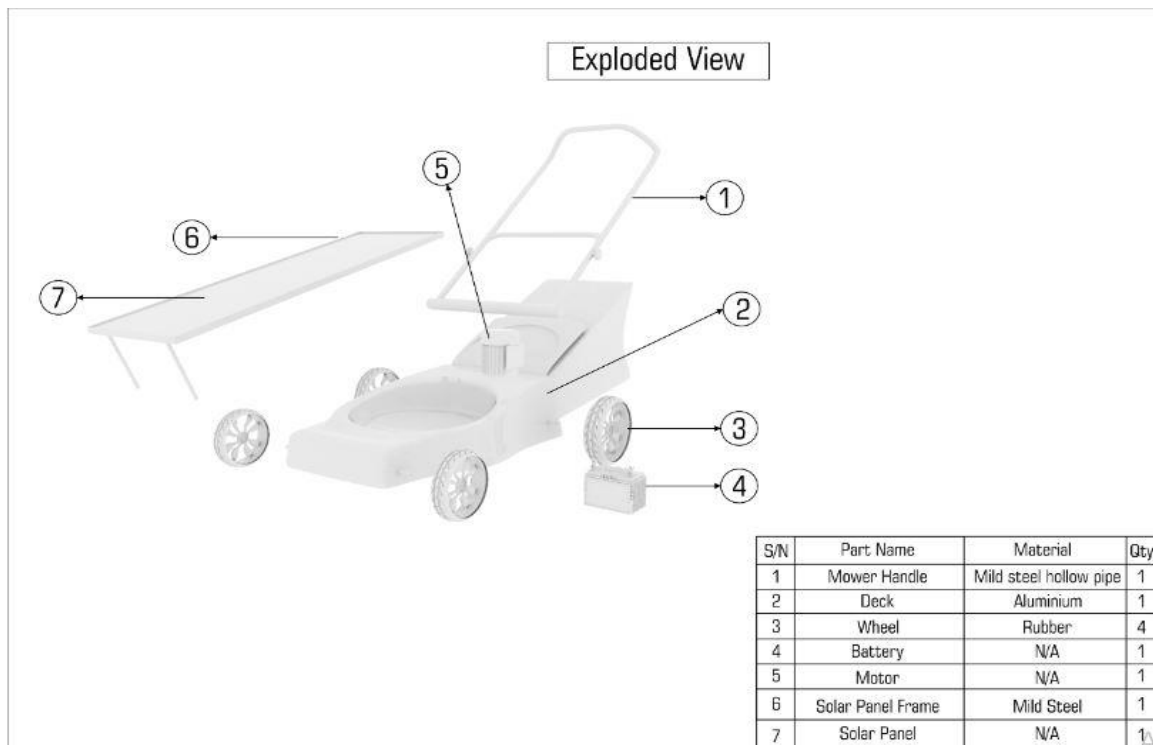
### 3.2 DESIGN CONCEPT



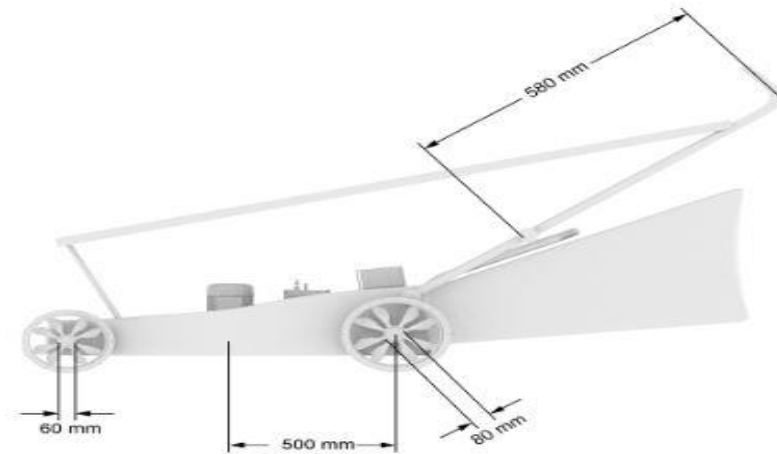
**Fig 3.1:Design concept**



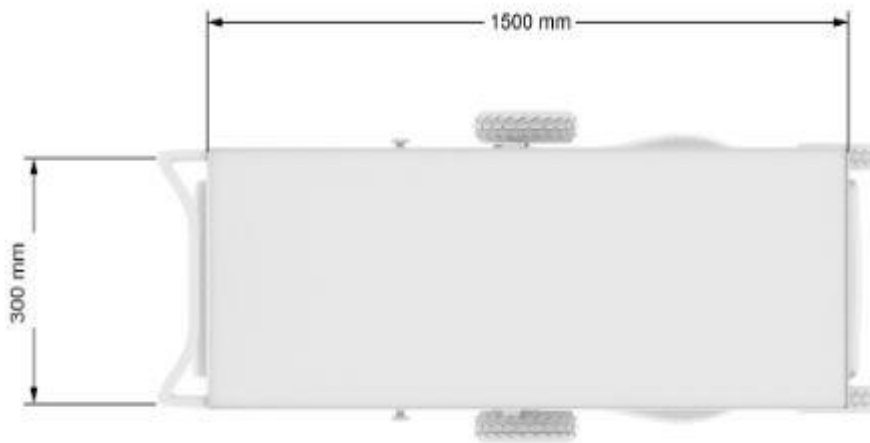
**Fig 3.2: Rendered view of the proposed lawn mower**



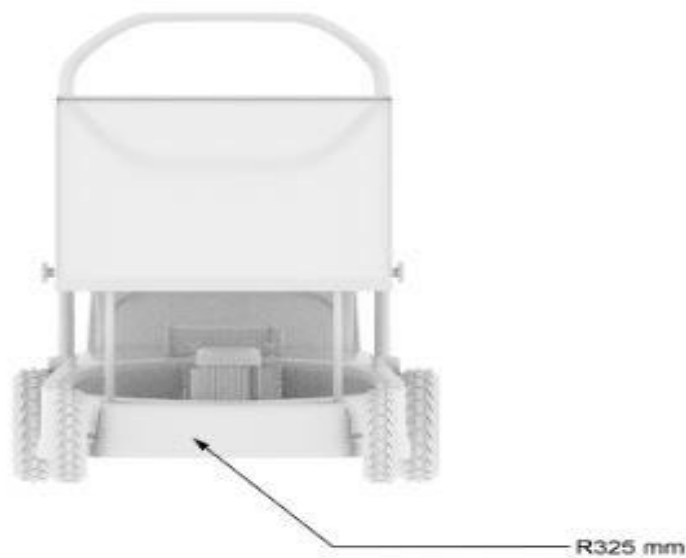
**Fig 3.2:Exploded view of the proposed solar lawn mower**



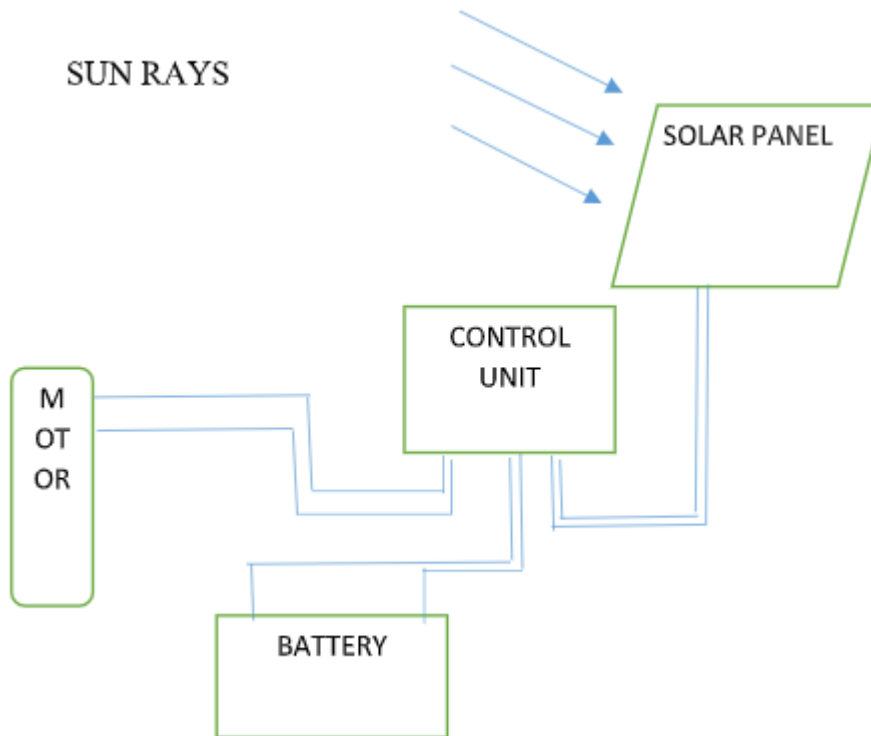
**Fig 3.3: Side view of the proposed lawn mower**



**Fig 3.4: Top view of the proposed lawn mower**



**Fig 3.5: Side view of the proposed lawn mower**



**Fig 3.6: Circuit Diagram of the solar lawn mower**

Solar energy is a time dependent energy that occurs at irregular intervals. Therefore energy has to be stored so it can be readily available for use when there is no further supply of the sun energy. The solar panel (or photovoltaic cell) harnesses the solar energy when the sun is available during the day. The sun produces constant amount of energy with a solar radiation intensity of about  $6.33 \times 10^7 \text{ W/m}^2$  at the surface of the sun. Photovoltaic modules and arrays produce direct-current (DC) electricity and current combination. Solar photovoltaic cells are essentially semi-conductors, which have electrical transmission properties like metal or salt water and insulators like rubber. Solar panels are constructed with sheets of doped silicon, primary element in beach sand with impurities added like phosphorus that allows the flow of electron.

To charge the battery, a solar panel is expected to tap the solar energy from the sun and convert it to electric energy that will be put away in the battery connected to it. At the point when the protons from the sunlight based energy hit a photovoltaic cell, a progression of electrons begins which can be drawn off by a connected wires, this generates direct current. Various sun oriented cells electrically connected with one another and mounted in a support structure or edge is known as a photovoltaic module. Modules are intended to flexibly supply a specific voltage. The current created is predominantly proportional to the amount of light striking the module.

A charge regulator that will be wired between the solar board and the battery is likewise required. The reason for the controller is to prevent the battery from the solar panel when there is no insulation or production of electricity. It likewise prevents excessive charging when the battery gets fully charged and furthermore controls the voltage getting to the battery.

In selecting the solar panel the following were considered;

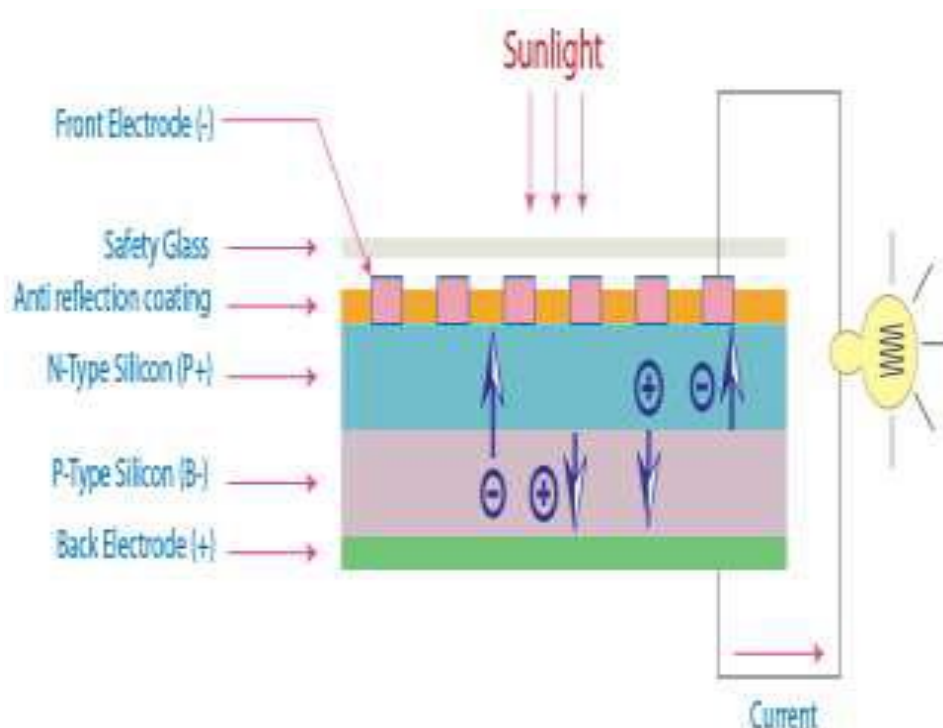
- i. The average sun hours per day (insolation).
- ii. Battery capacity
- iii. Current draw of the motor.
- iv. Mower operation duration

### **3.3 OPERATION PRINCIPLE**

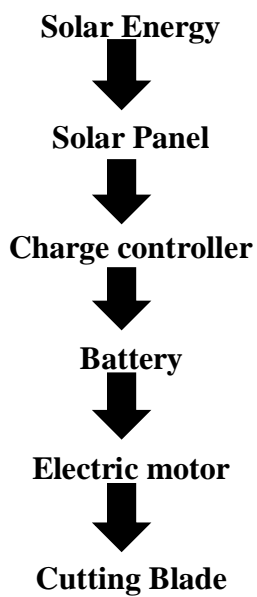
The photo- voltaic effect can be observed in nature in a variety of materials but the semiconductors performed best in sunlight.

The solar powered lawn mower involves the application of solar power to charge batteries for the purpose of using it to power an electric motor which in turn actuates the blade as the mower is being propelled. When the mower blade revolves it draws air in, fire air inlet located at different points outside of the mower. The air is drawn into the center of the blade, because the blade is rotating, the air is push down creating a high pressure rating of air underneath the machine. This high pressure rating creates lift, raising the mower on inclusion of air which also allows the mower to be easily maneuvered. When the mower moves, the lawn mower blades which are attached to the revolving electric motor cuts the grass. The electric circuit ensures solar energy from the sun is transferred through a charge controller to charge the battery which in turn supplies power to run the electric motor, while the solar panel power, will continuously recharge the battery while in operation. When the power switch is on, the electrical energy from the battery powers the motor which in turn actuates the blades. The solar panel generates current to recharge the battery, thereby compensating for the battery discharge. The solar lawn mower is made up of a lawn mower deck with handle, a 12volts electric motor; a 12 volts battery and blade. A charge controller is mounted separately used for charging the battery. The solar panel is a photovoltaic cell that generates current when light falls on its surface. 100 Watts solar panel is used to charge the battery. The electric motor forms the heart of the machine and provides the driving force for the blade.





**Fig 3.7: Photovoltaic principle**



**Fig 3.8: Flow diagram of the operation of solar lawn mower**

### 3.4 TABLE 3.1: MATERIAL SELECTION

S/N	COMPONENTS	MATERIAL SUITABLE	REASONS FOR SELECTION
1	Blade	Mild steel	Strength, Resistance to corrosion
2	Motor	DC motor	Easily accessible and economical
3	Battery	12V, 40Ah battery	Rechargeable, durability and economical
4	Charge controller		
5	Solar panel	100W	Functionality
6	Frame	Mild steel	Strength
7	Deck	Mild steel	Strength

### 3.5 CALCULATION

#### 3.5.1 POWER SELECTION

The required force necessary for cutting a grass shouldn't be lower than 10Newtons, this determined by different factors, which includes; Height of grass, grass type, height of grass and the grass density in area. However a much larger force would be required for improved efficiency.

#### 3.5.2 SOLAR PANEL SELECTION

The solar panel to be used for the solar lawn mower is a 12V, 100Watts panel which consists of 24 high efficiency solar cells resulting to high efficiency per space.



**Fig 3.9: Solar panel**

There solar panels consist of three basic types; monocrystalline, polycrystalline and amorphous solar cells. For the development of this project monocrystalline is used because it is more space efficient as it consists of lesser silicon crystals. The maximum output voltage produced by a silicon cell is approximately 0.5Volts when there is bright sunlight.

Solar panels need direct sunlight to produce greater solar output. Although in situations whereby the weather is cloudy, the solar panel can absorb solar energy but the rate will be significantly reduced to about 25 to 40% when compared to sunny days. The panels will only produce maximum output to charge the battery during the peak sun hours per day. Peak sun hours per day is approximately 4.86hours. Considering the power and voltage of the solar panel, the following calculations were made;

Power = 100W

Voltage = 12V

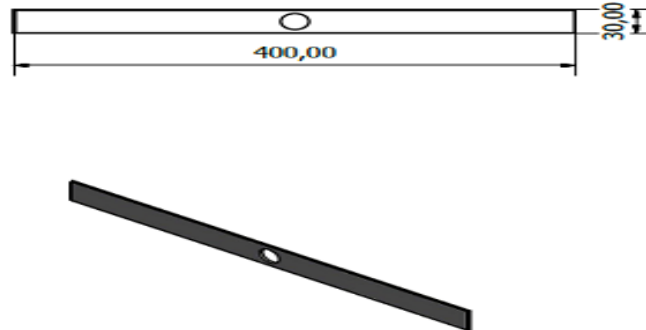
$$\begin{aligned} \text{Current draw of the solar panel} &= \text{power/voltage} & (3.1) \\ &= 100/12 \\ &= 8.33\text{Ah} \end{aligned}$$

From this derivation, it shows that the solar panel will give 8.33 amps of current.

### **BATTERY SELECTION**

Batteries are available in different voltages and ampere hour range. To determine the battery selection, consideration was given to the rating of the voltage and current. Since the solar panel is 12V, then a 12V

battery was selected. The ampere hour is used to measure the time the battery will take to discharge while it's not charging. A 40 ampere battery was selected and will give 40 amps of current of battery for one hour before it fully discharges.



**Fig 3.10: Mower blade**

**3.5.3 DIMENSIONS FOR THE BLADE**

Length = L = 400 mm

Breadth = 30mm

Thickness = T = 4 mm

speed of motor = N = 3000 rpm

Density =  $\rho = 7850 \text{ kg/m}^3$

Acceleration due to gravity =  $g = 9.81 \text{ ms}^{-2}$

**i. To the determine the area of the blade**

area of the blade = length \* breadth (3.2)

area of the blade = L \* B

area of the blade = 400 mm \* 30mm

= 12000 mm<sup>2</sup>

**ii. To determine the volume of the blade**

volume of the blade = area of the blade \* thickness (3.3)

volume of the blade = 12000 mm<sup>2</sup> \* 4 mm

= 48000 mm<sup>3</sup>

**iii. To determine the mass of the blade**

mass = density \* volume (3.4)

$$= 7850 \frac{\text{kg}}{\text{m}^3} * 4.8 \times 10^{-5} \text{m}^3$$

$$= 0.377\text{kg}$$

**iv. To determine the weight of the blade**

$$\text{weight of the blade} = \text{mass of the blade} * \text{acc due to gravity} \quad (3.5)$$

$$= 0.377 \text{ kg} * 9.81 \text{ ms}^{-2}$$

$$= 3.7 \text{ N}$$

**v. To determine the torque**

$$\text{radius of the blade} = \frac{\text{diameter}}{2} \quad (3.6)$$

$$= \frac{400 \text{ mm}}{2}$$

$$= 200 \text{ mm}$$

$$= 0.2 \text{ m}$$

$$\text{Torque} = \text{weight of the blade} * \text{radius of the blade} \quad (3.7)$$

$$\text{Torque} = 3.7\text{N} * 0.2 \text{ m}$$

$$\text{Torque} = 0.74\text{Nm}$$

**vi. To determine the angular velocity**

$$\omega = \frac{2\pi N}{60} \quad (3.8)$$

$$\text{where, } N = 3000$$

$$\pi = 3.142$$

$$\omega = \frac{2 \times 3.142 * 3000}{60}$$

$$= \frac{18852}{60}$$

$$= 314.2 \text{ rad/s}$$

**vii. To determine the power generated at the blade**

$$\text{power generated at the blade} = \text{Torque} * \text{angular velocity} \quad (3.9)$$

$$= 0.74\text{Nm} * 314.2 \text{ rad/s}$$

$$= 232.28 \text{ W}$$

$$= 0.23\text{KW}$$

**viii. To convert Kilowatt to Horsepower**

since 1KW is equivalent to 1.341 metric HP

therefore,

0.23 KW is equivalent to 0.3 Hp

For design purpose 1Hp will be used for this project, so that it provides the required torque in other to cut all types of grass effectively.

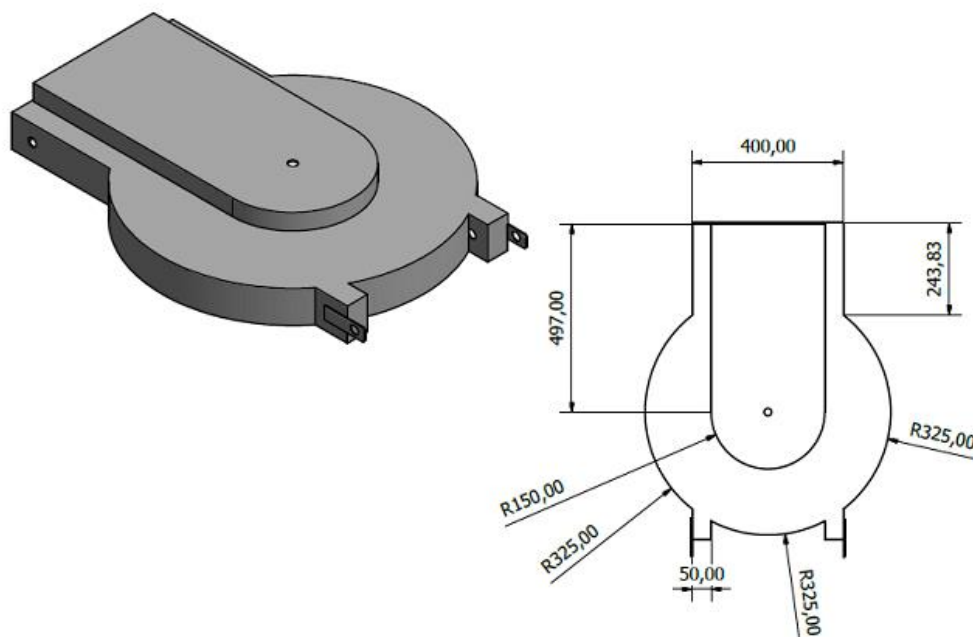
Hence, the centrifugal force according to Khurmi and Gupta (2000)

$$F_c = m\omega^2 r \quad (3.10)$$

$$\text{Hence, } F_c = 3.7 \times 314.2 \times 0.2$$

$$= 73.0 \text{ kN}$$

### 3.5.4 DESIGN FOR THE DECK



**Fig 3.11: Lawn mower deck**

A mild steel plate will be used for the design of the lawn mower frame due to its strength, workability, availability and cost effectiveness. The frame provides support for the electric motor, battery as well as the handle frame. The proposed diameter of the deck is 650mm and height 100mm. The deck is also made of one hand lever adjuster which are used to raise and lower the deck to the desired height of cut and it has a spin hook. It will transmit the load of 25kg to the wheel equally and length of each is 700mm.

Bending moment =  $\frac{PL}{4}$  where P is the load and L is length of the spin hook

where load P = mass \* acceleration due to gravity (3.11)

where mass (m) is 25kg and acceleration due to gravity (g) is  $9.81 \text{ ms}^{-2}$

Therefore,  $P = 25 * 9.81$

$$= 245.25 \text{ N}$$

since, the load will be equally distributed on the four wheels. Therefore, we have

$$\begin{aligned} \frac{\text{load}}{4} \\ &= \frac{245.25}{4} \\ &= 61.3 \text{ N} \end{aligned}$$

where P which is the load acting on each wheel is 61.3 N and L which is the length of the spin hooks is 700 mm. Therefore, the bending moment M would be ;

$$M = \frac{P * L}{4} \quad (3.12)$$

$$\begin{aligned} M &= \frac{61.3 * 700}{4} \\ &= 1072.75 \text{ Nm or } 1.073 \text{ KN} \end{aligned}$$

the yield stress of the mild steel is  $200 \text{ Nmm}^2$  and the ultimate stress is 0.53

$$\text{Allowable shear stress} = \text{ultimate stress} * \text{yield stress} \quad (3.13)$$

$$= 0.53 * 200$$

$$= 106 \text{ N/mm}^2$$

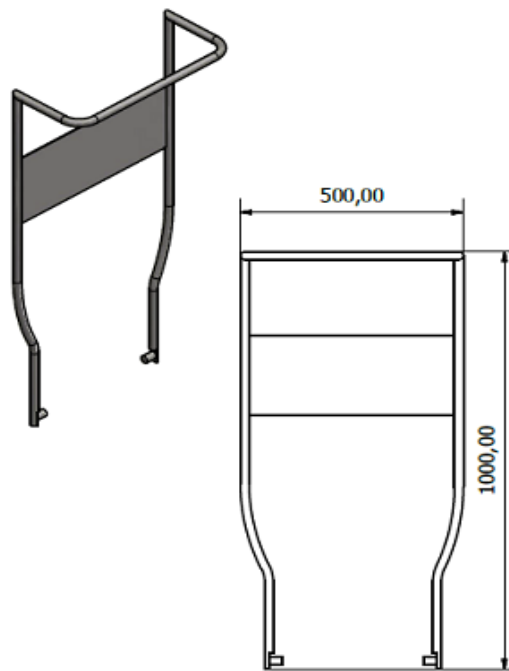
the sectional modulus (Z) according to khurmi and Gupta (2000).

$$\text{sectional modulus } Z = \frac{\text{bending moment}}{\text{shear stress}} \quad (3.14)$$

$$= \frac{1072.75}{106}$$

$$= 10.120 \text{ mm}^3$$

### 3.5.5 DESIGN OF THE HANDLE FRAME.



**Fig 3.12: Lawn mower handle frame**

The solar panel is placed on the peripheral of the handle, and the weight of the solar panel is 15kg. In order to accommodate the length of the solar panel, a length of 1200mm tilted at an angle of  $60^\circ$  was chosen. From Khurmi and Gupta (2000).

$$M = \frac{\sigma I}{y} \quad (3.15)$$

where:  $M$  is the bending moment.

$\sigma$  is the stress.

$I$  is the moment of inertia.

$y$  is the resolved length of the solar panel at an angle.

And also  $\sigma = 0.53y_s$

where  $y_s$  is the yield stress which is  $200\text{N/mm}^2$

shear stress =  $0.53y_s$

$$= 0.53 * 200$$

$$= 106\text{N/mm}^2$$

$$\text{the moment of inertia } I = \frac{\pi(D^4 - d^4)}{64} \quad (3.16)$$

where  $D$  is the outer diameter of the hollow pipe is 50 mm

$d$  is the inner diameter of the hollow pipe is 48 mm

$\pi$  is 3.142



$$\begin{aligned}\text{Therefore, moment of inertia } I &= \frac{3.142 * (50^4 - 48^4)}{64} \\ &= 46,219.8\end{aligned}$$

$$\text{Also, } y = x \cos \theta$$

where, x is the length of the solar panel which is 1000 mm

$\theta$  is the angle of inclination of the solar panel which is  $60^\circ$

$$\begin{aligned}\text{Therefore, the resolved length of the solar panel at an angle } y &= 1500 * \cos 60 \\ &= 1500 * 0.7071 \\ &= 750.00 \text{ mm}\end{aligned}$$

$$\text{Therefore, the bending moment } M = \frac{\sigma I}{y} \quad (3.17)$$

$$= 106 * \frac{46,219.8}{750.00}$$

$$= 6532.4 \text{ Nmm}$$

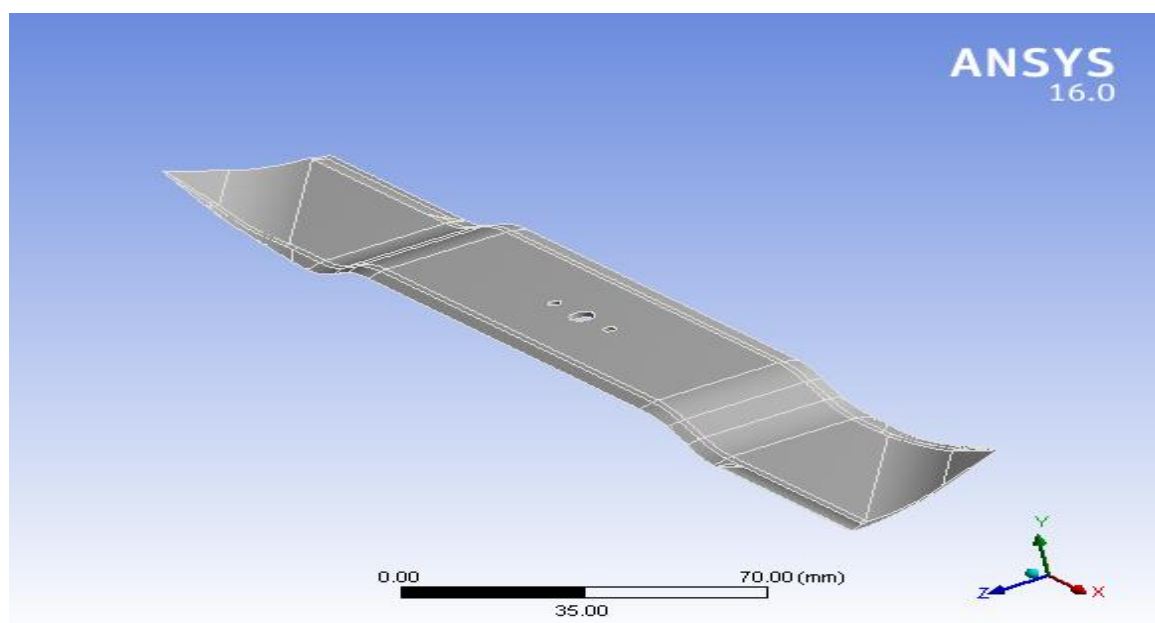
$$\text{sectional modulus } Z = \frac{\text{bending moment}}{\text{shear stress}} \quad (3.18)$$

$$= \frac{6532.4}{106}$$

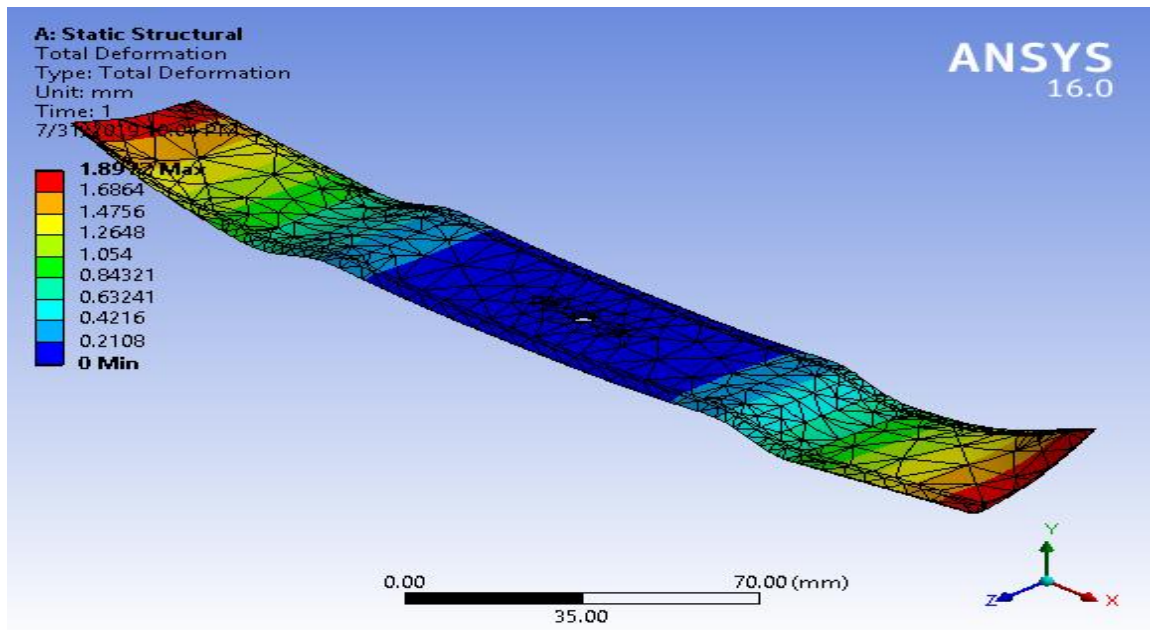
$$= 61.6 \text{ mm}^3$$

### 3.6 STRESS ANALYSIS

Stress analysis was done for the lawn mower blade and handle showing the total deformation and directional deformation that could occur while operating the machine. The analysis was done using ANSYS software.

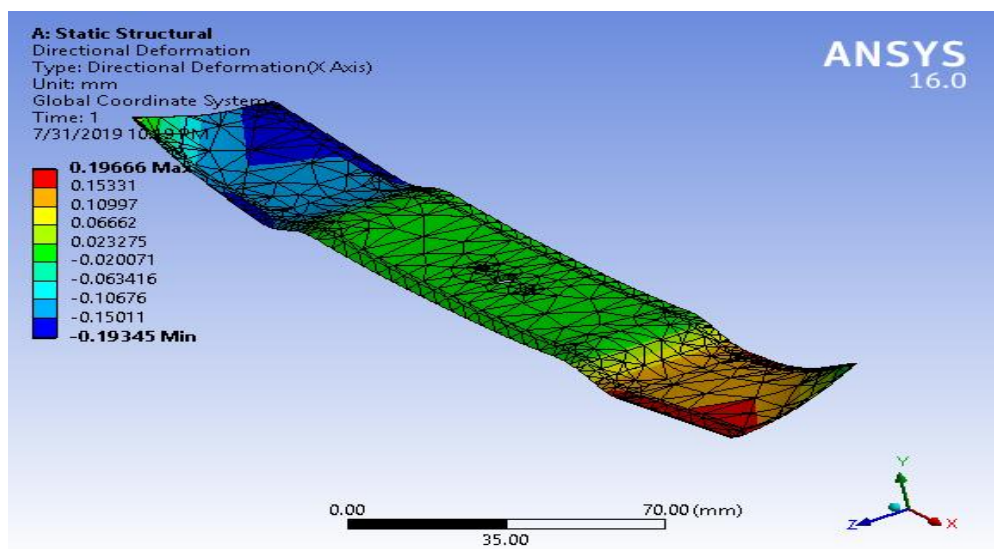


**Fig 3.13: Blade model**



**Fig 3.14: Blade model showing the total deformation**

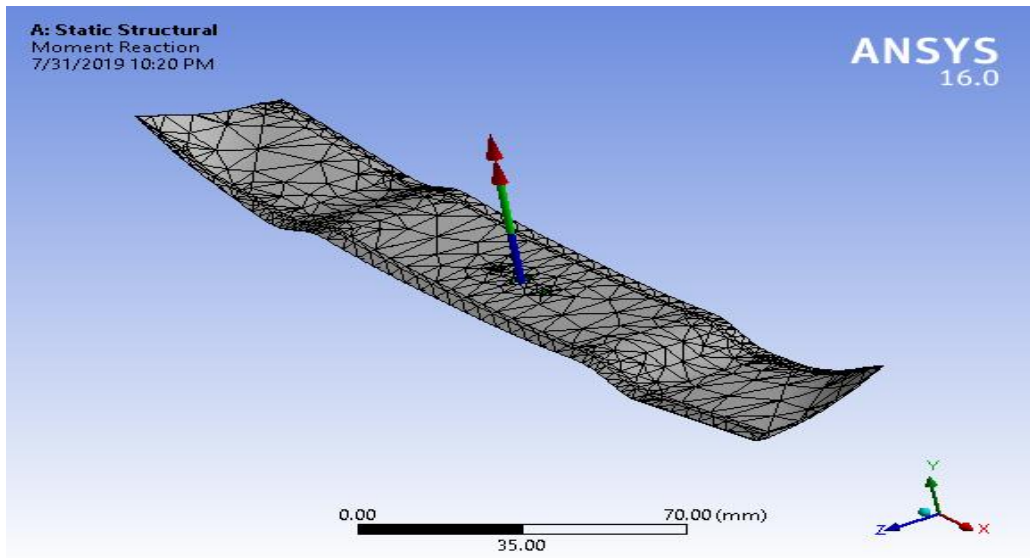
Fig (3.15) above shows the total deformation that could occur on the blade under thermal and load conditions. The analysis shows that the blade will experience minimum total deformation at the center of the blade while maximum deformation will occur at both ends of the blade.



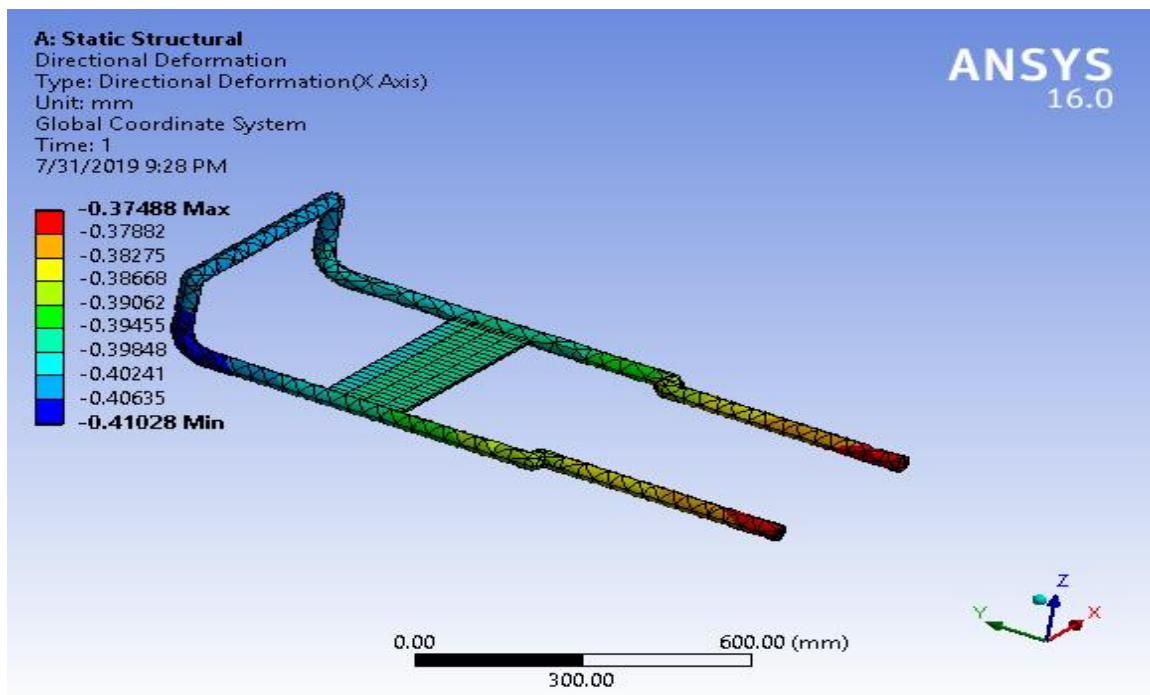
**Fig 3.15: Blade model showing the directional deformation**

Fig (3.16) shows the maximum and minimum directional deformation that could occur on the blade at the inclined axis of rotation. Maximum deformation will occur at one end of the blade at 0.1966mm while the

least possible deformation will occur at the other end of the blade at  $-0.1934\text{mm}$ . The reason for the different deformation values is due to the clockwise rotation of the blade.

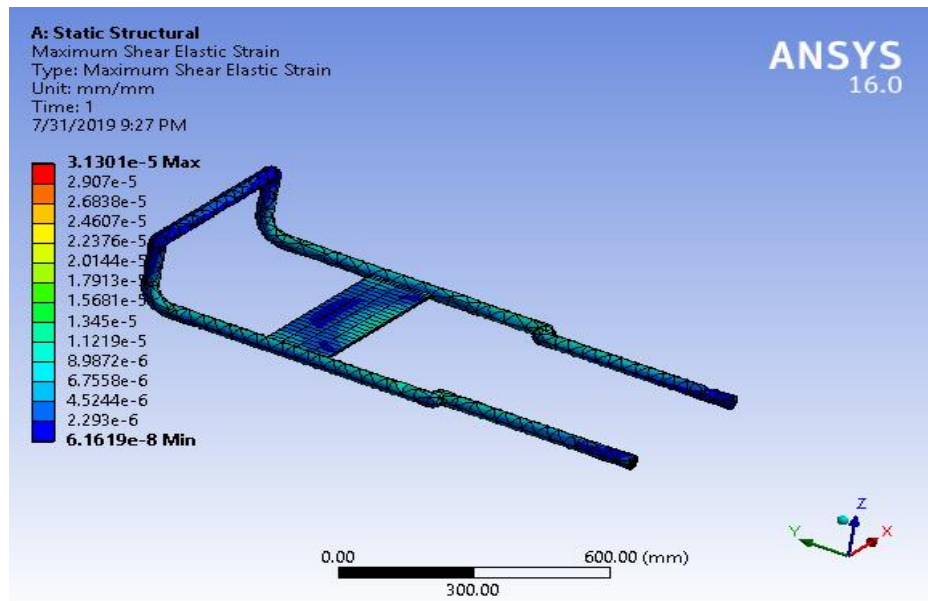


**Fig 3.16: Blade model showing the bending moment of the blade**



**Fig 3.17: Frame model showing the directional deformation**

From fig 3.18 above, the frame will exhibit the same deformation effect at both ends of the frame under load conditions.



**Fig 3.18**

From the above above analysis above we can say that the frame design is safe and able to transmit push and pull motion under the required loading conditions.

## CHAPTER FOUR

### RESULTS AND DISCUSSION

#### 4.1 IMPLEMENTATION OF FABRICATION PROCESS

The mechanical aspect comprises of several parts which are coupled together to form a frame for the solar panel, seat for the battery and the blade design. Mild steel of thickness (1mm) was used to design the rectangular top of the frame, supported by a hollow pipe at the four edges. The hollow pipes were placed in such a way as to provide an angle of tilt for the solar panel. The frame and supports were made suitable to carry the weight of the solar panel while the mower is being propelled during operation. The seat for the battery was also designed using mild steel of thickness (1mm) and was joined to the body of the deck using fasteners. The body of the deck area was made of aluminum making it impossible to carry out welding operations on the area. All joining processes on the deck was done using fasteners. A compartment on the deck area was designed to house the electric motor and blade beneath. The blade was made of mild steel material of thickness (4mm) and was incorporated to the shaft of the electric motor. The blade was designed in such a way as to create polarity when cutting grasses at different height and also to prevent the blade from wobbling. The blade was screwed directly to the shaft of motor so as to generate the speed transmitted from the motor to achieve efficient cutting operation. The fabrication process involved various manufacturing operations such as; marking out, cutting, grinding, shaping, drilling and welding. The mower design was made to have the least possible amount of welded joints.



**Fig 4.1: Fabricated model of a solar operated lawn mower**



**Fig 4.2: Front-view of the solar lawn mower**



**Fig 4.3: Back-view of the solar lawn mower showing the battery and charge controller.**

## 4.2 RESULTS

The solar powered lawnmower was fabricated and tested. During the machine operation electrical energy of the battery was converted to mechanical energy through the blade to achieve cutting operation. The electric circuit ensured that power was transferred from the battery to run the DC motor, while the solar panel continuously charged the battery during operation. The blade generated power from the DC motor at a speed of 3000rpm. When the switch is on, the electrical energy from the battery powers the motor which in turn actuates the blade. The solar panel generates current to recharge the battery, thereby compensating for battery discharge. The rotating blade continuously cuts the grass as the mower is being propelled. During the operation it was convenient to cut grasses at different height using an adjustable lever mechanism attached to the deck area of the machine.

## 4.3 BATTERY SIZING

After the solar lawn mower was developed, it took approximately 5 hours for the battery to completely charge the battery and the mower worked effectively for 50 minutes before discharging completely. The reason for the short working duration of the battery was due to the high current draw of the electric motor.

## 4.4 EFFICIENCY OF THE SOLAR LAWN MOWER

The efficiency of the machine is considered based on the total area covered and time taken. To calculate the forward velocity;

Forward distance = 30m

Time taken = 100s

Average forward velocity =  $30/100 = 0.3\text{m/s}$

### Field efficiency;

Theoretical Field Capacity (TFC) = forward speed x Theoretical width (4.1)

Theoretical width of the blade = 0.30m

TFC =  $0.30 \times 0.30 = 0.09\text{m}^2/\text{s}$

Effective field capacity (EFC) = total area covered/total time taken (4.2)

=  $65 \text{ m}^2/850 \text{ sec} = 0.076 \text{ m}^2/\text{s}$

Field efficiency =  $(0.076 / 0.09) \times 100$

=85%

#### 4.5 COMPARATIVE STUDY

Comparing the solar lawn mower to the conventional gasoline lawn mower, the following factors were observed;

**TABLE 4.1: Comparative study**

Conventional Mower	Solar Mower	Factor
Causes more pollution	Clean and pollution free	Air Pollution
Less	More	Effort
More	Less	Maintenance required
More	Less	Noise Pollution
Less	More	Efficiency
Complex	Simple	Construction

Table: 2

From the factors determined above, the solar operated mower will be used effectively in the following applications;

#### 4.6APPLICATIONS

- Used in gardens
- Used in play grounds
- Road side grass and small plant cutting
- Nursery applications

#### 4.7DISCUSSION

The efficiency of the solar lawn mower designed and developed is 85% which is well above average and this is due to the power output of the electric motor which drives the blade attached to the shaft of the motor.

The 100W solar panel is able to adequately charge the battery (40Ah), for a period of approximately 5 hours, which is being regulated by the charge controller, however, the speed of the motor which is 3000rpm rotates the blade causing it to cut the grass until the battery completely discharges.

From the result generated during the testing of the developed machine, it is environmentally friendly, in that there's zero emission of carbon monoxide and the noise generated is relatively low when compared with the noise generated by a lawn mower powered by internal combustion engine. Also, it was observed that the



battery was charging during the operation provided the sun shine continues to fall on the surface of the solar panel.

The fundamental reasons responsible for the power output which results into 85% efficiency of the electric motor are; the power rating of the solar panel, the speed (in rpm) of the electric motor used for the development and the size and material of the blade.

The electromechanical energy ratio between the electric motor and the blade is sufficient which results to the maximum efficiency of the solar lawn mower.

**TABLE 4.2: COST ANALYSIS**

S/N	ITEMS	SPECIFICATION	QUANTITY	RATE	COST
1	DC Motor	1H.P, 12V, 3000rpm	1	28,000	28,000
2	Charge controller		1	11,000	11,000
3	Switch		1	500	500
4	Lawn mower deck with handle		1	10,000	10,000
5	Battery	12V, 40Ah	1	18,000	18,000
6	Solar panel	100	1	23,000	23,000
7	Blade	1 X 1 Inch	1	2,000	2,000
8	Cables			500	500
9	Welding work				10,000
10	Painting				5000
11	Workmanship				10,000
12	<b>Total</b>				=118,000

**Table: 3**

**NOTE:** The unit of cost is in naira.

## **CHAPTER FIVE**

### **CONCLUSION AND RECOMMENDATION**

#### **5.1 CONCLUSION**

1. The design parameters of the solar lawn mower were studied and stress analysis was done on certain components parts of the machine
2. The solar lawn mower was fabricated
3. The solar lawn mower was tested and was effective enough to cut all types of grass at different heights.
4. Comparative study was done between the solar lawn mower and conventional gasoline operated mowers.

Conclusively, the design of the Solar powered Lawn mower is generally environmental friendly and also encourages environmental sustainability due to zero production of greenhouse gases, it also cost effective as solar panel requires little to no service cost compared to conventional gasoline operated lawn mower.

#### **5.2 RECOMMENDATION**

From the design and result generated, it can be recommended that a solar panel higher current draw should be used so as to completely charge the battery in a shorter period to enhance more working hours of the machine. A battery of more ampere-hours should be used also to enhance more working hours of the machine. The speed of the electric motor is sufficient enough to cut all types of grass which results to deriving maximum efficiency. Also, the design of the blade should be shaped such that it enhances better angle of cut.

Finally, an obstacle sensor should be incorporated to the machine so as to detect obstacles ahead while the machine is propelled forward to prevent it from causing wear on the surface of the blade and crack on the solar panel this would further enhance efficiency.

**REFERENCES**

- [1]. Ahamad, 2008. *Feseability Study on Design of Grass Removing Machine*, Melaka: University of Teknikal Malaysia.
- [2]. Atkins, 1984. *Lawnmower and Garden Equipment. Second Edition.*, s.l.: Creative Homeowner Press. UK..
- [3]. Bidgar, P. et al., 2017. Design and Implementation of Automatic Solar Grass Cutter. *International journal of advanced research in electrical,electronics and instrumentation engineering*, 6(4), p. 2433.
- [4]. D, S. & Ramalingeswara, 2015. Design and Fabrication of lever operated Solar Lawn Mower and Contact Stress anaysis of Spur Gears. *International journal of Science, Engineering and Technology Research*, 4(8).
- [5]. Khurmi, R. & Gupta, J., 2000. *Theory of machines*. Delhi: Eurasia Publishers limited.
- [6]. Kumar, D. et al., n.d. *Design and Fabrication of Smart Solar Lawn Cutter*, s.l.: university B D T college of engineering.
- [7]. Kumar, D. P. et al., n.d. *Design and Fabrication of Smart Solar Lawn Cutter*, s.l.: university B D T college of engineering.
- [8]. K, V., K, P., R, S. & A, S., 2015. Fabrication and Analysis of Lawn Mower. *International Journal of Innovative Research in Science, Engineering and Technology*, 4(6), p. 606.
- [9]. Mohammad, M. S., Ahmad & Prof, 2018. Design and fabrication of two wheeler operated sickle bar mower. *International Research Journal of Engineering and Technology*, 05(10), p. 530.
- [10]. M, S. M. & Ahmad, P. K., 2018. Design and fabrication of two wheeler operated sickle bar mower. *International Research Journal of Engineering and Technology*, 05(10), p. 530.
- [11]. Ogiemudia, O., 2016. Design and Improvement of a Solar Powered Lawn Mower From Locally Sourced Material. *ELK Asia Pacific Journals*, 2(1), p. 1.
- [12]. P, B. et al., 2017. Design and Implementation of Automatic Solar Grass Cutter. *International journal of advanced research in electrical,electronics and instrumentation engineering*, 6(4), p. 2433.
- [13]. Satwik, D. & Ramalingeswara, 2015. Design and Fabrication of lever operated Solar Lawn Mower and Contact Stress anaysis of Spur Gears. *International journal of Science, Engineering and Technology Research*, 4(8).
- [14]. Singh, M. et al., 2016. A review and comparative analysis of solar, electric and gasoline lawn mowers: An extensive study. *International journal of innovative science, engineering and technology*, 3(4), pp. 371-375.
- [15]. Tanimola, Diabana & Bankole, 2014. Design and development of a solar powered lawn mower. *international journal of scientific & engineering research*, 5(6), pp. 216-217.
- [16]. Venkatesh, K., Priyanka, K., Sridhar, R. & Sakthivel, A., 2015. Fabrication and Analysis of Lawn Mower. *International Journal of Innovative Research in Science, Engineering and Technology*, 4(6), p. 606.

**APPENDIX 1**



**FABRICATION PROCESS OF THE SOLAR LAWN MOWER**



**FABRICATED SOLAR LAWN MOWER**