

Automated System for Effective Control of Electrical Supply of Houses Using Image Processing

Mitali Potnis

Department of Electronics Engineering
K. J. Somaiya College of Engineering
Mumbai, India.

Chaitanya Phadtare

Department of Electronics Engineering
K. J. Somaiya College of Engineering
Mumbai, India.

Shreyas Parkar

Department of Electronics Engineering
K. J. Somaiya College of Engineering
Mumbai, India.

Nirmala Baloorkar

Prof., Department of Computer Engineering
K. J. Somaiya College of Engineering
Mumbai, India.

Pradnya Bhangale

Prof., Department of Computer Engineering
K. J. Somaiya College of Engineering
Mumbai, India.

Abstract:- With the introduction of “smart homes” and the integration of automation systems to control a given space’s functioning, we see an evolving need to optimize the integrated automation systems to meet the intelligence and controllability level of the client. The most appealing automation systems are the ones based on power usage and control. Current systems available in the market for automating electric switches are primarily based on either infrared or proximity sensors, which are either inefficient or expensive in more extensive system settings. Our proposed system uses image processing to control switches of electrical appliances in the room. Our system first captures the images of the room and further processes it before applying the Tiny Faces Algorithm on it, which will determine the positions of the individuals present in the room. Using this obtained data will generate control signals to the raspberry pi, which will further trigger the relay circuit, thus triggering an automatic ‘switching ON’ of the electrical appliance connected to this system. The result of the proposed system is nearly 92% accuracy. This simple, efficient, and cheaper system helps to optimize the power consumption of the house and helps to save energy.

Keywords:- Image Processing, Home Automation, Face Detection, Tiny Faces algorithm, Raspberry pi.

I. INTRODUCTION

In the 21st century, with virtually every sector undergoing automation, there is an increasing demand for a home automation system that reacts to its surroundings. People prefer that tasks be done mechanically via robots or different automation systems over manual control. Following this demand, many automation systems have been developed. The most prominent being in the sector of power supply and usage, where automated control may help prevent unnecessary power usage or wastage. Current systems available in the market for automating electric switches are primarily infrared, proximity sensors, or other similar sensors [1]. Although these systems are convenient, they have a flaw that underlies the fact that the sensors detect human

movement or other related parameters, which, when upscaled, can either prove to be inefficient or expensive or both. To circumvent this problem, we have devised a new method that uses image processing as a tool to sense the presence of individuals in a given space. Our system detects and captures individuals’ faces in the room to control electrical switches in the room.

Our proposed system uses Face Detection to enable automated control of the power supply in the houses. It employs a series of cameras attached to either the ceiling or the wall. The strategic position of the cameras is optimized to ensure the best coverage of the room. The system’s back-end processing involves capturing images of spaces after a stipulated interval in time, followed by storing and processing the captured images using the Tiny Faces Algorithm [2]. The Tiny Face Algorithm detects the individual faces with an added advantage over the other algorithms like MTCNN (Multi-task Cascaded Convolutional Neural Networks) [3], Haar Cascades [4], in that it can accurately recognize the faces of the individuals which are positioned at a distance from a camera even in a large population. The algorithm is trained using a ResNet101-based Machine Learning model to detect human presence from the real-time feed from the camera. Any presence of individuals will thus trigger an automatic ‘switching ON’ of the electrical appliance connected to this system. To enhance efficiency and accuracy, we have integrated contrast enhancement using histogram equalization to detect individual faces even with minimal or no light. Based on the individual or crowd’s position in the room, a hardware prototype generates signals that control the electricity that helps to optimize the power usage of the connected appliance.

II. LITERATURE REVIEW

Image processing is one of the optimal techniques to control the power supply. Venkatesh K. and Kumar Sarath [5], in their work, focused on using image subtraction to detect the presence of the people in the room. Image subtraction is a process wherein the digital numeric value of one pixel or whole image is subtracted from another image

[6]. Ganiger *et al.* [7], in their work, used background subtraction where Raspberry Pi (a series of small single-board computers) is used to detect the motion of objects by comparing the reference image and the current image captured by the camera. If any motion is detected, then the algorithm relays a signal to raspberry pi to turn on the initialized GPIO (general-purpose input or output) pin, which triggers additional relays that turn on the main power supply. Although the method using Image Subtraction to detect the presence of humans in the room is efficient, it lacks accuracy. Face detection gives better accuracy when compared to Image Subtraction. The system proposed by Varma *et al.* [8] consists of a Machine Learning model used to train the Haar classifier to detect faces of the humans present in the room from the real-time feed from the camera. The data is further processed and sent to the parallel port DB-25 present in the computer, relaying a signal to the power source to control the power supply. One of the open challenges in face detection is the detection of people positioned far away from the camera. P. Hu and D. Ramanan D. [9] tackle another caveat of detecting small objects or faces, which are crucial in a large field as a classroom. The result is achieved by scaling the image at the 1x,2x, and 0.5x size and detecting the faces in every scaled image. The results, once combined, give the detection of large to small faces. The model is trained with 25 templates on the WIDER's FACE training set. The result of this method is nearly 99% of face detection.

III. METHODOLOGY

The general flow for the entire proposed system is shown in Fig. 1.

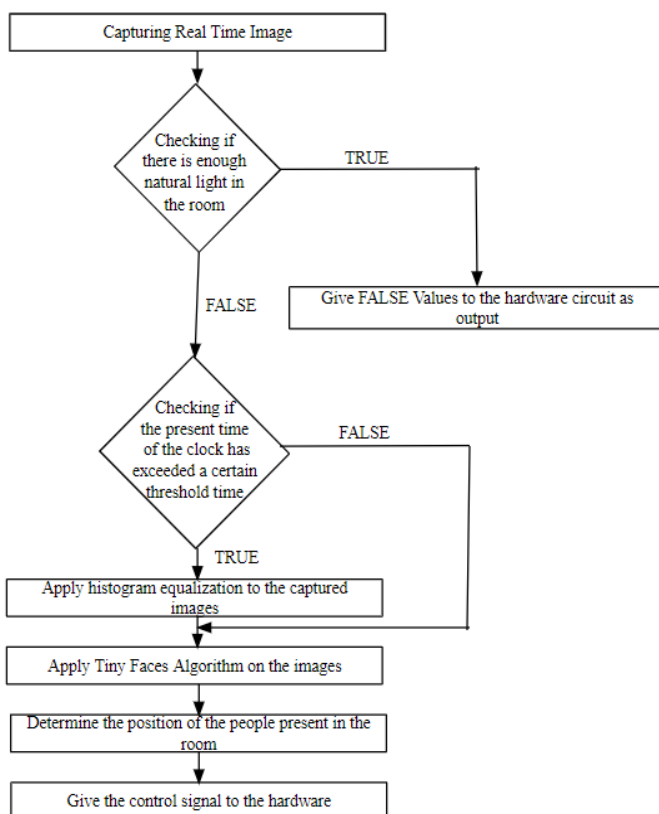

Fig. 1. General Framework

A. Image Acquisition

The first stage, image acquisition, consists of retrieving an image from any hardware-based source like a digital camera or a camera sensor, following which the captured image undergoes image processing. For our current study, we have chosen a stationary Raspberry Pi Camera Module for capturing the photographs of the rooms. The camera model utilized is an eight-megapixel Sony IMX219 image sensor that is designed for Raspberry Pi. The camera was in turn connected to the CSI interface port of the Raspberry Pi, which is one of the small sockets on the board's upper surface. The camera captures images of a resolution of 3280 x 2464 pixels. The two crucial parameters here are the position of the camera and the angle of the camera. The advantage of our method is that it can detect faces even in images of lesser resolution to some extent. For our application, we captured the real-time images of the rooms after 15 seconds.

B. Brightness detection and Contrast Enhancement

1) Brightness Detection

To save energy, we decided to omit switching on the lights in the presence of enough natural light present in the room. This concept was implemented by first converting the colorspace of the captured images of the room from RGB (Red-Green-Blue) to HSV colorspace. Here, HSV stands for Hue-Saturation-Value, wherein the 'Hue' is the color, 'Saturation' is the greyness which will tell us dull or dim looking the caught picture is, and 'Value' is the brightness of the pixel. We then decided on a threshold value of brightness, which will prohibit the use of the face detecting algorithm on the captured images when satisfied by the mean value of the brightness of all the pixels. This process will relay an output of FALSE (0) values to the hardware, thereby not causing any triggering of the electrical switches. This process will prevent the connected light switches from being switched ON during the daytime or in the case of enough light present in the room, hence, helping reduce the wastage of energy.

2) Histogram Equalization

Although the system was able to detect faces in the presence of light, accurately detecting faces in the dark or low light exposure was going to create obstacles. To overcome this issue, we implemented histogram equalization. Histogram equalization is a method in image processing used for contrast enhancement [10]. It is achieved by effectively spreading out the most frequent intensity values, i.e., it stretches out the intensity range of the image. This adjustment allows the proper distribution of the intensities on the histogram. Thus, areas of lower local contrast can achieve a higher contrast. This method is favorable for images with backgrounds and foregrounds that are both bright or both dark. The original image (Fig. 2a) gives a color histogram with the improper distribution (Fig. 2b). After the application of histogram equalization, the image is clearly visible (Fig. 2c) with a color histogram following a normal distribution (Fig. 2d). The color histogram of the original image (Fig. 2b) also shows that the dynamic range of the gray-level of the captured image increased to cover the full range of gray levels. The side-by-side comparison (Fig. 2e) displaying the initially captured image and the resultant image obtained after

applying histogram equalization shows a significant improvement in the quality of the captured image.

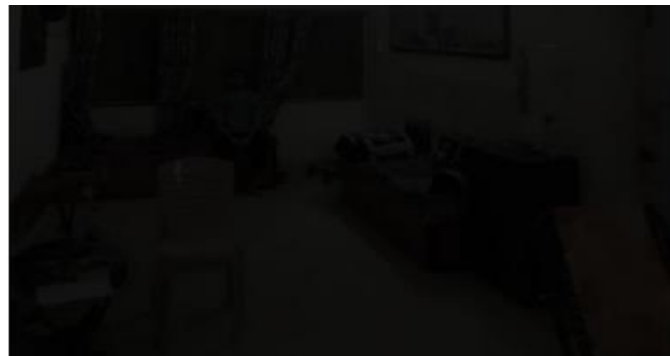

Fig. 2a. Originally captured image

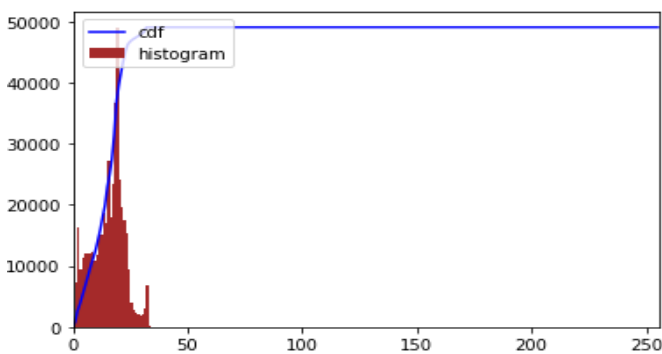

Fig. 2b. Color histogram for the corresponding captured initially image shown in Fig. 2a



Fig. 2c. Image obtained after applying histogram equalization.

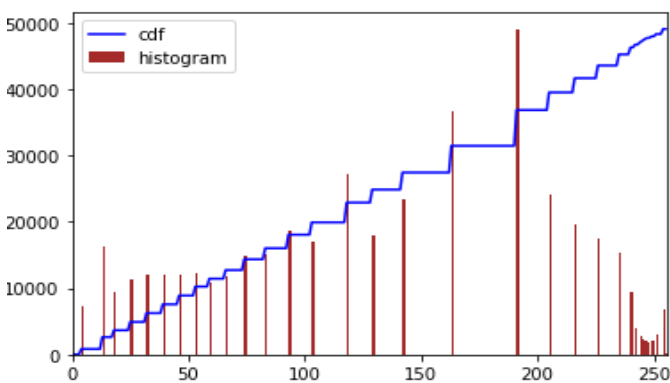

Fig. 2d. Color histogram of the corresponding resultant image seen in Fig. 2c



Fig. 2e. Side-by-side comparison of the initially captured image and the resultant image after applying histogram equalization.

C. Face Detection

In a large room, it gets challenging for the face detector to detect the faces of those individuals who are positioned far from the camera. With a large population of people present in the room, all the faces of the people present there fail to be detected by the conventional face detection algorithms like Haar Cascades and MTCNN. Hence, to accurately detect the presence of the people in the room, we implemented the Tiny Face algorithm for detecting their faces. The algorithm utilizes a ResNet101-based Machine Learning Model, a residual neural network that is 101 layers deep. The model is trained based on the WIDER FACE dataset [11], containing 32,203 images which consist of 393,703 different faces and high variability in the features like scale, pose, and occlusion. The canonical bounding box shapes are derived by using the K-medoids clustering. K-medoids is a partitioning clustering technique wherein the data set of n objects is split into K clusters. The Tiny Face algorithm significantly outperforms the other face detection algorithms. We compared results from the Tiny Faces algorithm with that of MTCNN and Haar Cascades (Fig. 3 a-c; Table 1). As demonstrated, the number of faces detected using the Haar Cascades algorithm was only one, whereas the actual number of people present in the room was two. When we used the MTCNN algorithm (Fig. 3b), the number of detected faces was three when the number of people present in the room was only two. In comparison, the number of faces detected in using the Tiny Faces algorithm accurately matches the number of people present in the room. During the numerous tests carried out by us, we observed that most of the other algorithms had few discrepancies regarding the number of faces detected when the captured image consisted of a person looking sideways or not facing the camera. This problem does not occur when we make use of the Tiny Faces algorithm.

TABLE I. RESULTS OF THE FACE DETECTION ALGORITHMS

Name of the algorithm implemented	Number of people present in the room	Number of faces detected using the algorithm
Haar Cascades	2	1
MTCNN	2	3
Tiny Faces	2	2



Fig. 3a. Faces detected using the Haar Cascades Algorithm.



Fig. 3b. Faces detected using the MTCNN algorithm.



Fig. 3c. Faces detected using the Tiny Faces algorithm

A. Image Segmentation

The process of Image segmentation consists of partitioning or splitting an image into multiple segments. It is used to determine the location of objects and boundaries in images. After partitioning the image, we can further process it to determine the position of each person present in the

captured image. Each fan or light of the room covers a specific area. Based on this coverage area, we split the image into different sections wherein each section is the area covered by each of the lights or fans. Based on the number of fans and lights, the images were segmented in such a way so as to optimize coverage. In the current case, the room had two lights, one to the left side of the room and the other to the right. Therefore, we divided the image into two regions based and labeled these sections as 1 and 2, respectively (Fig. 4). The regions are decided solely based on the area covered by the lights or fans.



Fig. 4. Partitioned Image

B. Generating Control Signals to the Hardware

Once the faces of the individuals present in the room are detected and their respective positions are determined, we need to send the respective control signals to the hardware.

1) Raspberry Pi 3

The Raspberry Pi 3 is a cost-effective, portable, small-sized computer that provides a set of GPIO (general purpose input/output) pins that allow you to control various electronic components. We have utilized Raspberry Pi 3 Model B, which has an M2837 64bit CPU and has 40-pin extended GPIO pins, 1GB RAM, CSI camera port, Micro SD card port. We used Raspberry Pi 3 (Fig. 5a) to receive the control signals and trigger the relay that controls the main power supply. If there are any faces detected in the room, based on their positions, the algorithm sends Raspberry Pi a message that someone present in the room. In response to this, the initialized GPIO pin will turn on, which will trigger the relay circuit.

2) Relay Circuit

To relay the circuit, we used a 2-Channel Relay Board. 2-Channel Relay Board is a relay interface board used to switch devices from the main supply and can be controlled

directly by GPIO pins of microcontrollers such as Arduino, RPI, and ARM. The Trigger operation for the relay which we are using usually is open. When we give Logic 1 to relay, the lights will turn ON, and on logic 0, it will turn OFF. Based on the signals received from the Raspberry Pi module, the relay circuit is triggered, which will switch ON or OFF the main power supply (Fig. 5b).

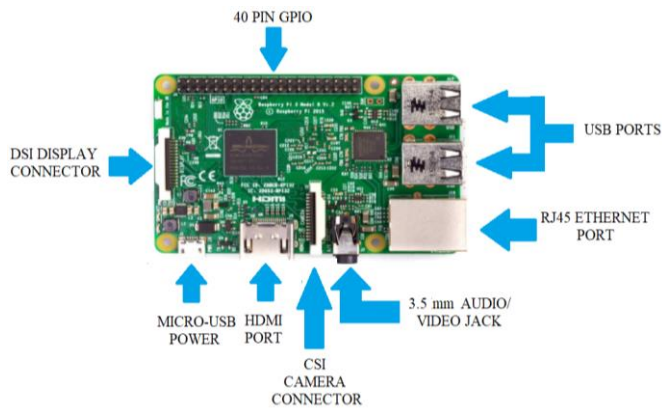

Fig. 5a. Raspberry Pi 3 Model

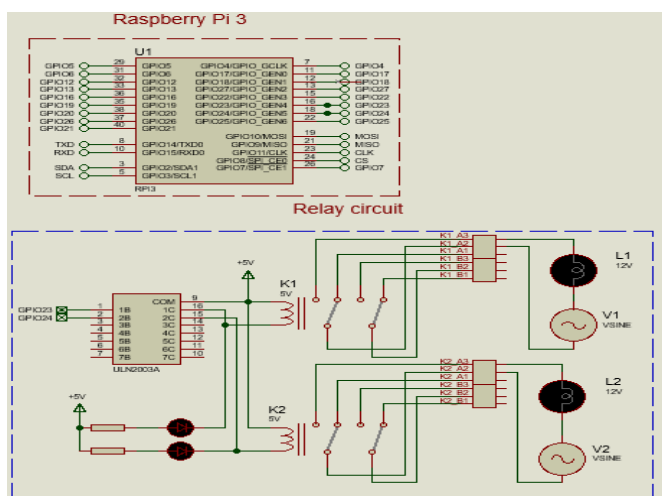

Fig. 5b. Wiring Diagram of the Raspberry Pi and Relay Circuit.

IV. RESULTS AND DISCUSSIONS

We carried out various test cases (Fig. 6 a-d; Fig. 7 a-d). The first case (Fig. 6a) was a captured image taken during the daytime in a room with only one light located at the center of the room, and only one person is present in the room. The second case (Fig. 6b) was of an image captured during the daytime where two people were present in the room, which consisted of two lights; one on the left side of the room and the other on the right side, which covered the respective portions of the room. Our third test case (Fig. 6c) consisted of an image captured during the night with a single person present in the room with only one light located at the Center. Finally, for our last test case (Fig. 6d), the image of the room was captured during the night time with no one present in the room, and the room had two lights located on the left portion and the other on the right portion of the room. In our first case, with the detection of the person’s face, the only light in the room was switched on (Fig. 7a; Table 2). For

the second case where two individuals were sitting on either side of the room, based on their positions, both the lights were switched on (Fig. 7b; Table 2). As for the third case, histogram equalization was applied to the image, which was further processed, giving us one detected face, which switched on the light (Fig. 7c; Table 2). In the last case, since no person was present in the room, neither of the two lights was switched on (Fig. 7d; Table 2).



Fig. 6a. Image captured during the daytime with only a single person present in the room and two lights in the room



Fig. 6b. Image captured during the daytime with two people present in the room and only one light in the room

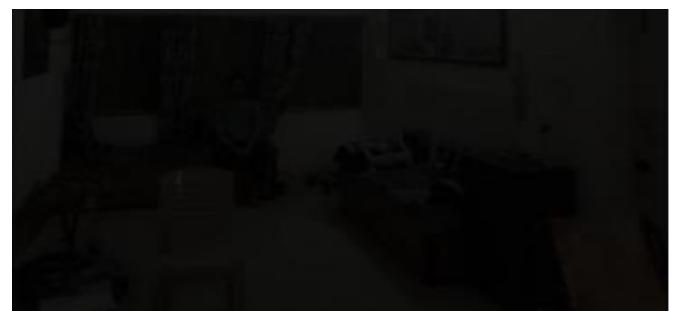

Fig. 6c. Image captured during the night time with only one person present in the room and only one light in the room



Fig. 6d. Image captured during the night time with no one present in the room and two lights in the room



Fig. 7a. Detected result for fig. 6a



Fig. 7c. Detected result for Fig. 6c



Fig. 7b. Detected result for fig. 6b



Fig. 7d. Detected result for Fig. 6d

TABLE II.
RESULTS OF THE TEST CASES

Test Case	Number of people present in the room	Number of faces detected	Number of lights in the room	Position of the lights in the room	Lights switched ON
1	1	1	1	Light 1: Center of the room	Light 1
2	2	2	2	Light 1: Left side of the room Light 2: Right side of the room	Light 1, Light 2
3	1	1	1	Light 1: Center of the room	Light 1
4	0	0	2	Light 1: Room's Left Side Light 2: Room's Right Side	No lights switched ON

V. CONCLUSION

In conclusion, Image Processing using Face Detection is a better approach to control the power supply of electrical appliances like lights, fans, lamps, and air conditioners. Our system has proved to have higher accuracy when compared to similar technology that employs sensors or methods like Edge Detection. The result of the proposed system is efficient sensing of individuals present in a room with nearly 92%

accuracy. By implementing this system, we can optimize power consumption and help conserve energy.

VI. FUTURE SCOPE

For our future scope of this study, we could incorporate emotion recognition for controlling the lighting in the room as per the individual's mood. One drawback of the proposed system is that the accuracy of the face detection during the

night time decreases by a tiny percentage (nine out of ten images get detected). This limitation could be overcome by using a better method to process the images captured during the night time to get detected with increased accuracy.

ACKNOWLEDGMENT

We would like to express our deepest gratitude to our project guides: prof. Nirmala Baloorkar and prof. Pradnya Bhangale; for their patient guidance, enthusiastic encouragement, and valuable critiques throughout this project. We also offer our sincere appreciation for the learning opportunities and software provided by our college. Our completion of this project could not have been accomplished without the support of our peers Ritwik Mandal, Madhura Shegaonkar, Anoushka Shetty, and Tanmay Pawar.

REFERENCES

- [1]. Petrova N., Vershinin A., Abramchuk S., and Pugovkin A., "Automation of Monitoring the Thermal Conditions in a Room" *Energy Procedia*, vol. 95. pp 358–365. October, 2016. Accessed on: June, 5, 2020, doi: 10.1016/j.egypro.2016.09.022
- [2]. F. Ye, M. Ding, E. Gong, X. Zhao and L. Hang, "Tiny Face Detection Based on Deep Learning," *2019 14th IEEE Conference on Industrial Electronics and Applications (ICIEA)*, Xi'an, China, 2019, pp. 407-412, doi: 10.1109/ICIEA.2019.8834282.
- [3]. Sachan A., "Real time deep learning based face detection using Tensorflow". CV. [Online] Available: <https://cv-tricks.com/face-detection/real-time-deep-learning-mtcnn/>. Accessed 13th June 2020.
- [4]. Viola P. and Jones M., "Rapid object detection using a boosted cascade of simple features," *Proceedings of the 2001 IEEE Computer Society Conference on Computer Vision and Pattern Recognition. CVPR 2001*, Kauai, HI, USA, 2001, pp. I-I, doi: 10.1109/CVPR.2001.990517.
- [5]. Venkatesh K. and Sarath K., "Automatic Real Time Auditorium Power Supply Control using Image Processing". *Proc. of Int. Conf. on Information Technology in Signal and Image Processing. Association of Computer Electronics and Electrical Engineers*, 2013, doi: 03.LSCS.2013.6.524
- [6]. Pixel subtraction. (n.d.). Retrieved August 20, 2021, from <https://homepages.inf.ed.ac.uk/rbf/HIPR2/pixsub.htm>
- [7]. D. Ganiger, K. A. Patil, P. Patil and M. Anandhalli, "Automatic Control of Power Supply in Classroom Using Image Processing," *2017 International Conference on Recent Advances in Electronics and Communication Technology (ICRAECT)*, Bangalore, India, 2017, pp. 230-234, doi: 10.1109/ICRAECT.2017.16.
- [8]. Varma S., Taduri G., Sai B., 2013, "Automatic Electrical Appliances Control Based on Image Processing", *International Journal of Engineering Research and Technology (IJERT)* Volume 02, Issue 09, September, 2013.
- [9]. Hu P. and Ramanan D., "Finding Tiny Faces," *2017 IEEE Conference on Computer Vision and Pattern Recognition (CVPR)*, Honolulu, HI, USA, 2017, pp. 1522-1530, doi: 10.1109/CVPR.2017.166.
- [10]. Garg P. and Jain T., "A Comparative Study on Histogram Equalization and Cumulative Histogram Equalization", *International Journal of New Technology and Research (IJNTR)*, vol. 3, no. 9, September, 2017. doi: 4.10.5121/sipij.2013.4502.
- [11]. Yang, S., Luo, P., Loy, C. C., & Tang, X. (2016). "Wider face: A face detection benchmark", *2016 IEEE Conference on Computer Vision and Pattern Recognition (CVPR)*. doi:10.1109/cvpr.2016.596