

# A Review of Antenna Design and Gain Importance in 5G mm Wave Beam Forming Applied at Quadrature Baseband Versus RF

Lusungu Ndovi, Charles. S. Lubobya, Ackim Zulu.

**Abstract:-** This review paper looks at Antenna gain for beamforming for 5G mmWave networks. Beamforming is a very key aspect of 5G networks and coupled with MIMO, it will be able to accommodate the much needed functionalities of 5G mmWave Technology. Several related works by other researchers are reviewed. In the research a Quadrature baseband (QBB) beamforming approach is presented as a possible solution to this challenge. ODFM signals are used in the MatLab simulations to be able to compare results at RF versus QBB. On-going research in this area entails that it is possible to have an optimal solutions to the aspect of antenna gain and solve some of the challenges being faced as the 5G network system roll out continues. Antenna design challenges are expected with which impacts on propagation losses and calls for best beamforming configurations.

**Keywords:-** Beamforming; Quadrature baseband; Antenna gain, 5G Networks, mm Wave;

## I. INTRODUCTION

Antenna gain is the ability of the antenna to radiate more or less in any direction compared to a theoretical antenna[1]. 5G being the latest wireless technology will ensure billions of devices get connected and hence the need to take care of all the critical requirements of this technology that is currently being rolled out.[2]. mmWave frequencies are very high with very short range and hence issues of attenuation must be attended to. Signal loss mitigation measures include use of beamforming, massive MIMO and ensuring that topological aspects when doing the roll out are taken care of to ensure optimized performance of the 5G systems. 5G-roll out challenges in this area of antenna gain optimization is still being carried out even as the 5G roll out

This work is supported by the Zambia's Ministry of Higher Education Scholarship research Fund.

L. Ndovi is with the School of Engineering, Department of Electrical & Electronics Engineering, University of Zambia, Box 37392, Zambia, (e-mail: lusungu.ndovi@gmail.com).

C. S. Lubobya is with the School of Engineering, Department of Electrical & Electronics Engineering, University of Zambia, Box 37392, Zambia, (e-mail: cslubobya@unza.zm).

A. Zulu is with the School of Engineering, Department of Electrical & Electronics Engineering, University of Zambia, Box 37392, Zambia, (e-mail: ackim.zulu@unza.zm).

is in process to ensure the short comings of the expected challenges are worked on. The main challenge of antennas at these frequencies is high path loss entailing that the gain of an antenna operating at these frequencies should be high. High gain in itself means that the beamwidth has to be low, hence reducing the coverage. This is where QBB comes in. It's therefore a trade-off between gain and beamwidth, which needs to be considered by the antenna designers [3]. Directional antennas can be configured with gains up to more than 20 dB. With billions of devices expected to be connected to the 5G networks, antennas must be highly directional. This is one requirement if MIMO systems are to be highly effective. A noted negative aspect of extreme gain antennas is their sensitivity to improper position displacement due to wind conditions. A variety of configurations that can result in good directional RF signal transmission do exist[2]. Antenna gain and directivity are closely related. The efficiency of an antenna is also related to its directivity. This is called the absolute gain [2]. Antenna gain measures the maximum effectiveness with which the antenna can radiate the power delivered to it by the transmitter towards a target. [3].

The next section of the paper discusses related work on antenna gain and beamforming in 5G.

## II. RELATED WORK

Naqvi *et al* [2] demonstrates an integrated multiple-input multiple-output (MIMO) antenna solution for Long Term Evolution (LTE) and Millimeter-Wave (mm-wave) 5G wireless communication services. In their work, a structure comprising of a two-element LTE MIMO antenna, and a four-element 5G MIMO configuration with rectangular and circular defects in the ground plane is proposed. The modeling of the mm-Wave 5G antenna follows after the design process [2].

Khattak *et al* [4][5] looked at beamforming and beam steering applications by proposing a low profile, wideband and high gain Substrate Integrated Waveguide (SIW) Transmission Line (TL) Butler Matrix (BM) beamforming network (BFN) for beamforming and beam-steering applications at 28 GHz (5G). They were able to show four distinct beams steering between  $-50^\circ$  to  $50^\circ$  with sidelobe and return-loss level below -10 dB were generated by connecting the proposed BFN to microstrip antennas forming a phased

array antenna. The antenna gain was good and can sustain the 5G requirements at such frequencies.

Muzaffar *et al* [3] proposed a compact metamaterial loaded Vivaldi antenna for 5G wireless cellular networks. In their design, the ground plane was corrugated as a way of preventing the surface currents from flowing outwards. This resulted in an additional antenna gain enhancement. The proposed antenna has an aperture efficiency of 78%.

Dusopt *et al* [6] proposed a V-band switched beam antenna having features like linear polarization, self-pointing pointing features for use in point-to-point communications. The research was able to produce experimental results showing a gain of 33.4 dBi, an aperture efficiency of 48% and a 3-dB bandwidth of 15.4%.

Park *et al* [7] proposed 8 types of antenna arrays at 28GHz based on different configurations. They discuss the performance of 2 by 2 MIMO antenna arrays in a reverberation chamber. polarizations[8]. After analysis the results showed that the antenna arrays have similar antenna performance with respect to the same array size, except for the polarization [7]. Several researchers propose different approaches towards antenna gain optimization. Theoretical versus practical output results is key to proving the ensure outcomes of the research carried out. In this work Antenna gain is analyzed for 5G mmWave networks based on other research carried out. A Quadrature baseband (QBB) beamforming approach coupled with antenna gain analysis of RF vs QBB is proposed. The research analyzes other works and proposes the use of MatLab simulations to carry out the analysis.

### III. LITERATURE REVIEW

#### A. 5G mmWave Beamforming

Rahimain *et al* looked at mm-Wave beamforming at RF. mm-Wave beamforming networks incorporate two types of array feeding systems. These are; lens-based and circuit based beamformers. In the process of generating multiple beamforming using an array, the aspect of RF beam steering capability is important coupled with having a wide beamwidth. This enables 5G wireless systems to have control over the phase and amplitude at each element of the array[9]. The researchers proposed a novel and high-performance Rotman lens beamformer and this was used to assess the feasibility of beamforming realisation using inkjet technology for use in 5G mm-Wave systems. In the research by the authors in [9], RF Beamformers are used. Our research proposes use of QBB Beamforming and compare it with RF outputs for similar conditions.

#### B. 5G mmWave Antennas

Fig.1 below shows a 5G mmWave antenna. In this antenna design, the effective range of the radio waves reduces due to wave length reduction. As is well known, 5G mmWave means very high frequency and short range signaling. Simultaneous connections are thus very important in these. Due the use of Beamforming, a reduction of

interference with other base stations is expected. Bandwidth increase is another expected benefit.

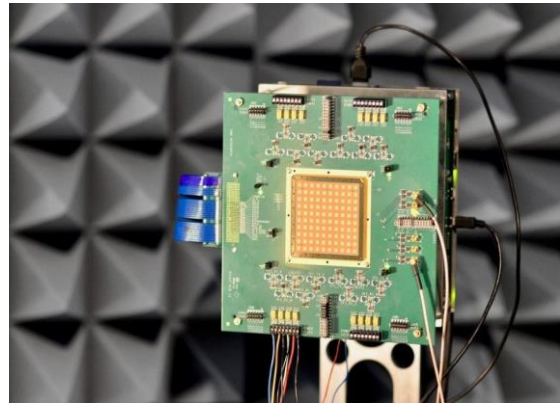

**Fig.1:** 5G mmWave Antenna (source: IBM research)

Kausar *et al* proposed the use of smart antenna technology to create a beamforming technique that would be much more efficient. This research proposed a mathematical model used for the design of a hybrid-beamforming antenna. The antenna beam being steered by a hybrid of switched parasitic and phased array approach. Each approach has its own advantages and disadvantages but a combination of the two brings out the best in antenna performance. The scenario in conventional beam steering for switched parasitic array antennas is that the beam steering is not continuous [10].

The figure below shows the beam pattern produced by the research done by the authors in[4],[5]. The resulting pattern shows that the low sidelobe levels obtained are good through there was some distortion due to the losses in the k-connectors hence causing a distortion in the peak gains. It is still good to note though that the maximum beam steering angle remains un-affected.

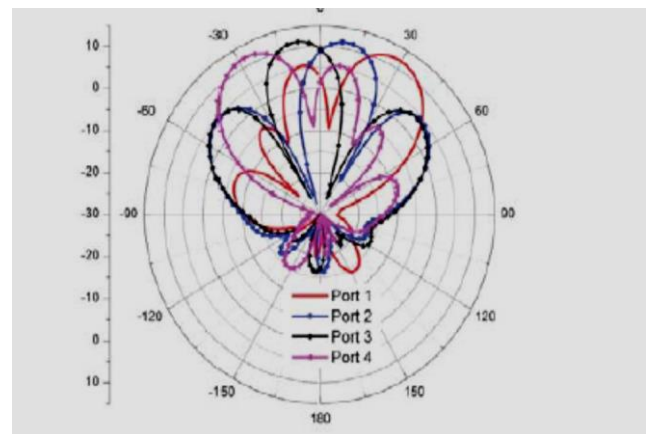

**Fig.2:** Measured 2D radiation pattern [4]

Yasin *et al* investigated and analyzed the Bessel beamformer mathematical model on the aspect of antenna automatic gain control. In this particular scenario, different direction but same carrier frequency and two users are used. One is a desired user and the other two are interferers. From the obtained simulation results, the modified Bessel beamformer results in an optimum solution which is able to

accommodate more users due to the smart antenna array implementation for base stations in a mobile 5G communication system[11]. In most, applications, we always endeavor to come up with a smart way of applying technology. Hence equally in 5G technology, the term ‘smart’ comes into perspective as researchers try to come up with the best possible configuration of antenna elements to be able to come up with the desired beams, coverage and antenna gains. The authors in [11] also came up with an adaptive beamforming algorithm which is able to update the weights dynamically and optimized the SNR of the antenna through the use of a modified Bessel beamformer. Fig.3 below shows the smart antenna configuration. The Bessel beamformer with automatic gain control and provides adaptive weights calculation efficiently.

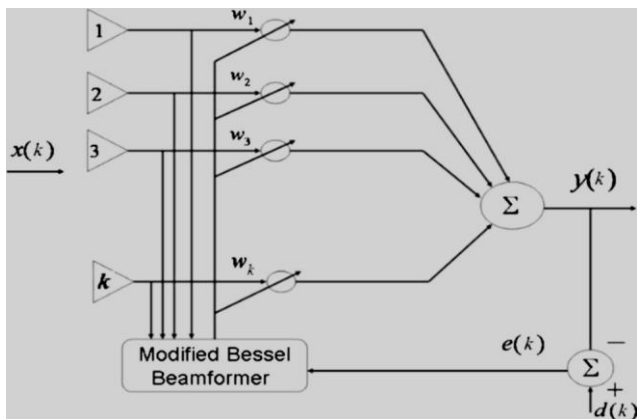

Fig.3: Smart adaptive antenna array system [11]

Li *et al* present the aspect of the spectrum of mmWave having unique advantages which present design challenges for 5G communication systems. There are several factors like system speed, capacity and network coverage which are key in this technology. The conventional RF system architecture needs modification in order to be able to tackle these challenges and hence the need to come up with modified antenna designs and systems [12]. When looked at critically, beamforming and MIMO tend to be interchangeable. However, beamforming is actually a subset of MIMO.

Wang *et al* presents the aspect of the fact that mmWave communication is considered as a key enabling technology for 5G cellular networks. This is in line with the abundance of mmWave spectrum in the multi-gigabit spectrum[13]. This operates using RF components. It investigates energy efficient analog beamforming in mmWave single-group multicast communication systems. The authors focused on a max-min fair problem with the aim of designing an analog RF beamformer to maximize the antenna signal to noise ratio output. The authors also investigated (SNR) over all users subject to a transmit power constraint. The analog problem of infinite and finite resolutions of PSs to come up with a low complexity algorithm for determining each element of the RF analog beamformer is tackled. The simulation results show the effectiveness of the proposed RF beamforming performance analysis for RF systems. The resulting asymptotic performance shows optimal performance[13].

C. Antenna Gain and Topology

5G antenna range is limited by the aspect of the high 5G frequencies. This means that short range high powered signaling is expected. Antenna gain for 5G mmWave comes to the lime light and substantial researches have been carried in this area. Antennas and their topological arrangement are a key aspect in the 5G network rollout. Qorvo [12] demonstrates a 5G network with multiple smaller cells that cover specific areas and they get connected to a central core network [8]. This brings to light the fact that 5G antennas must be able to live up to their expectations of having a high antenna gain to ensure that signal coverage reception/coverage is at its optimum. Fig.4 below courtesy of Qorvo [12] illustrates this.

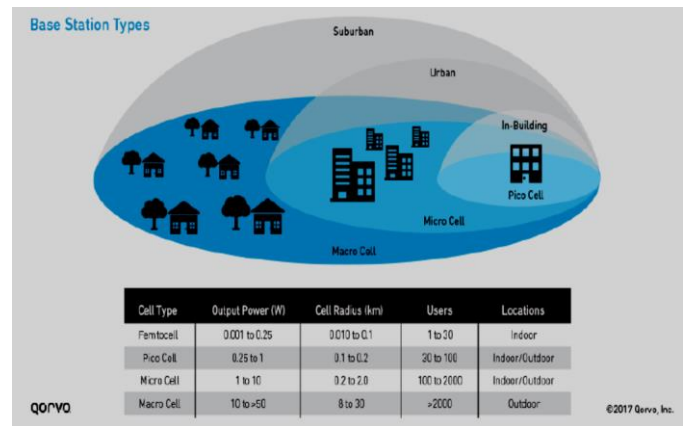

Fig. 4: Base station types and Topology [10].

D. Antenna Gain model plots

The mathematical modeling of the antenna gain calculation is given in the equations below. The authors in [2] managed to produce the graphical results showing the radiation patterns below;

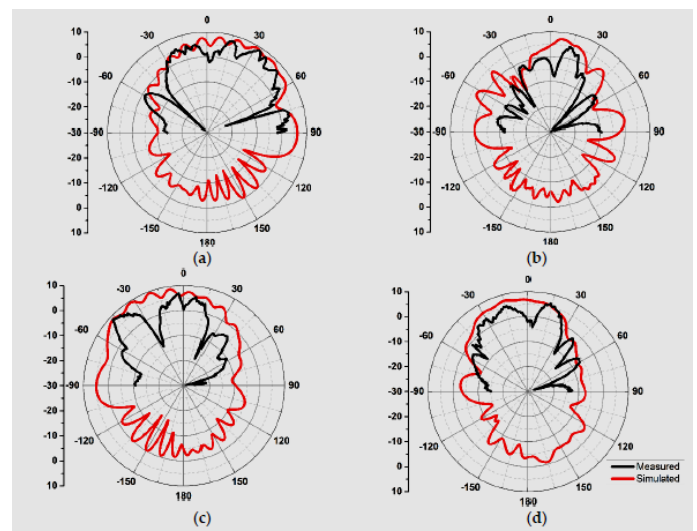

Fig. 5: Graphical plots for 5G radiations patterns for Ant 3 and Ant 6 in the XZ ((a),(c), and XY (b),(d) planes [2].

In the above plots,

The table below shows the resulting gain and efficiency outputs.

| Frequency (GHz) | Ant # | Peak Gain (dB) |          | Radiation Efficiency (%) |          |
|-----------------|-------|----------------|----------|--------------------------|----------|
|                 |       | Simulated      | Measured | Simulated                | Measured |
| 5.9             | Ant1  | 3.7            | 5.13     | 73                       | 71       |
|                 | Ant2  | 3.8            | 4.86     | 79                       | 83       |
| 27.5            | Ant3  | 10.14          | 9.43     | 79                       | 71       |
|                 | Ant6  | 9.37           | 9.49     | 69                       | 72       |
| 28              | Ant3  | 9.89           | 9.53     | 76                       | 73       |
|                 | Ant6  | 9.7            | 9.31     | 73                       | 68       |

**Table 1:** Measured gain and efficiency outputs [2]

The differences between the simulated and measured peak gains and radiation efficiency speak to the fact that the designed antennas had a good performance. The frequencies used are in the 5G spectrum and hence the significant contribution of this research.

*E. Antenna gain and Beamwidth*

The authors in [8] measured realized gain and beam widths and the results are summarized in the illustration below.

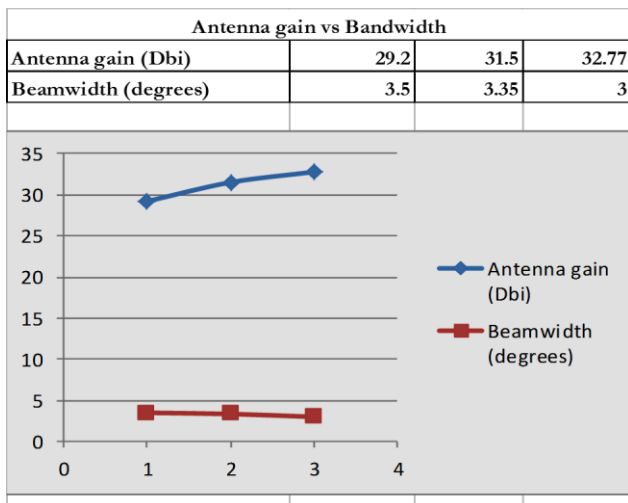

**Fig 6:** Antenna gain and Beam width relation [8]

The plot below illustrates the outcome.

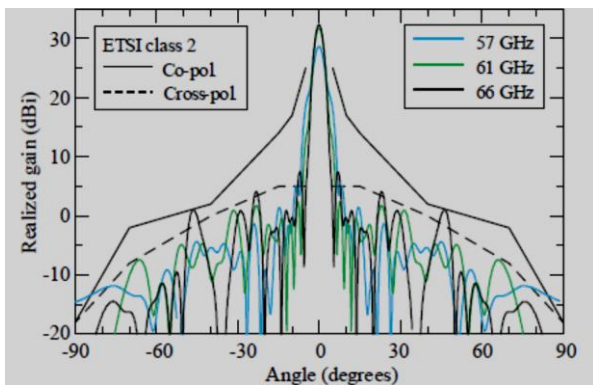

**Fig. 7:** Fixed beam transmit array E-plane for co- and cross-polarization [14].

In the figure below, a switched beam transmit array simulation and experimental results are presented at 61GHz in the H-plane

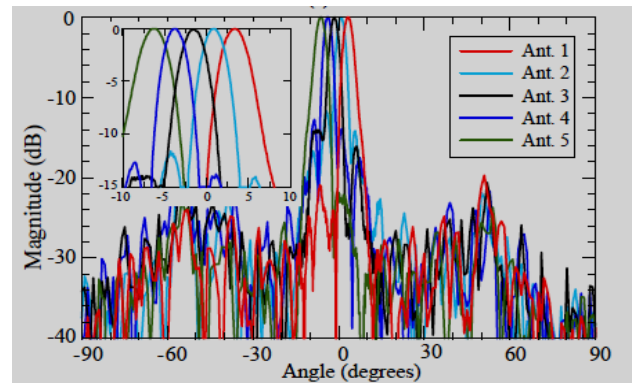

**Fig. 8:** Switched beam transmit array E-plane for co- and cross-polarization at 61GHz [15].

Optimized beamforming has been shown in this research. The antenna gain was optimized and the difference clearly seen between the switched beam and fixed beam patterns. It is known that the receiving antenna is different from the transmitting antenna in terms of parameters. Mathematical modeling involving the use of Chebyshev and Taylor have been used with it being evident that the distributions are not suitable for a thinned array due to its irregular spacing between array elements [16].

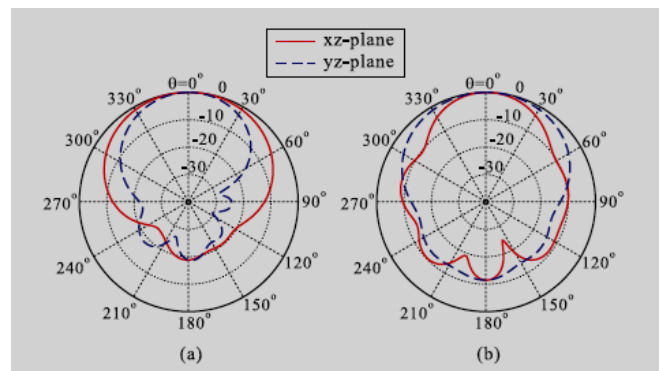

**Fig 9:** Simulated radiation patterns of antenna elements [16].

Based on the literature view covered, it very easy to see that there is so much research going on in this area and hence justifies our proposed research in the same field and results expected to present simplified option to getting optimal antenna performance results.

In antennas, the aspect of beamforming has an analogy to spatial filtering. This is capable of steering the beam peak of phased array antenna by having analog or digital techniques. RF analog beamforming has limitations. The antenna gain gets to be affected. Digital beamforming techniques are a remedy to this. It enables multiple beams to be generated in several directions and hence enhancing the antenna gain [17]. Based on the experimental results of the authors in [17], the came up with the following beam patterns show below.

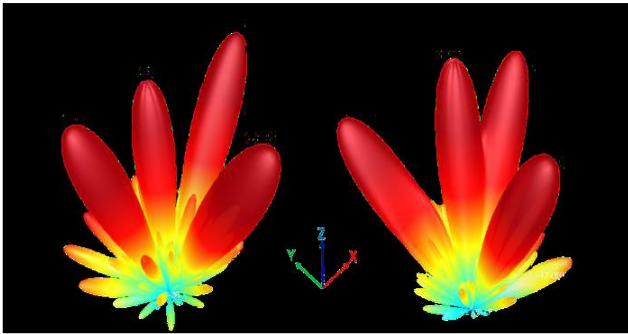
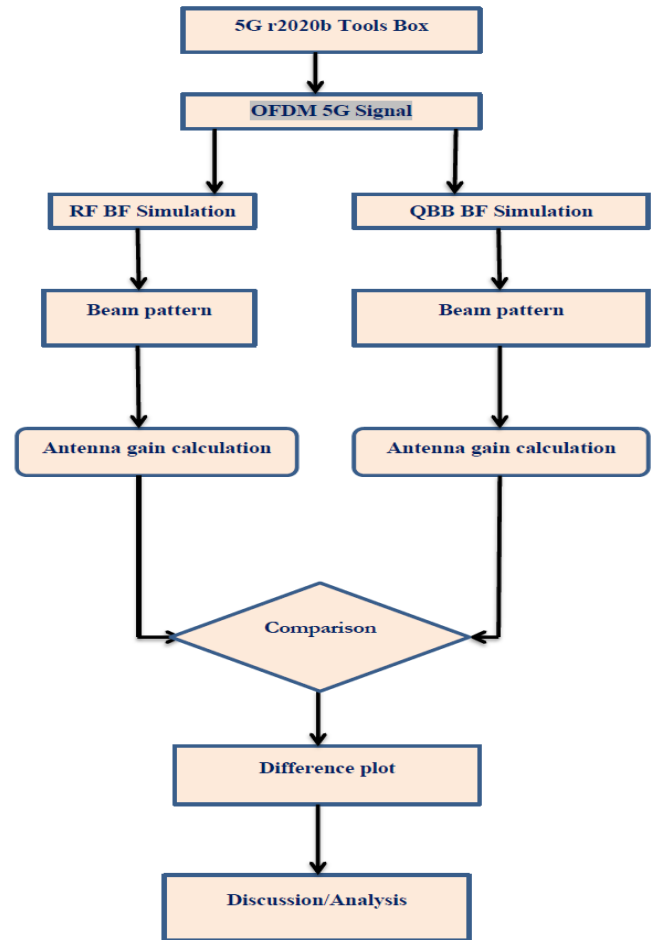

**Fig.10:** Multiple Beams at 5.3GHz Top and Bottom [17]

From these results, it can be seen that the simultaneous multiple beams having a 16 by 16 massive MIMO array panel could be independently steered for both the top and bottom dipole arrays. This resulted in a peak directivity of scan positions for different directivity for simultaneous users. This comes at a cost of large data processing and increased system complexity.

**IV. PROPOSED IMPLEMENTATION METHODOLOGY**

In carrying out this investigation Antenna gain importance of beamforming at Quadrature baseband for 5G mmWave networks a 64-bit Laptop computer with an Intel (R), core (TM) 13 CPU processor satellite pro C850-F41K. The computer has been installed with MATLAB version 2020[11]. This version of MATLAB has inbuilt 5G MATLAB tools box functions to generate and propagate OFDM simple signal for the analysis. Results will be presented and analysis of the achieved results from implementing the flow in figure 1 given to prove the proposed solution and alternative. When transmitting signals, beamforming enables a radio channel to direct the signals towards a specific user. This enhances throughput and bandwidth effective usage. This research investigates QBB as one useful approach to achieving this expected outcome. The 5G r2020b MatLab tools box generates the 5G OFDM Modulated signals that are fed into the RF and QBB algorithm systems for further processing. In our model, we were able to show beam patterns that show the aspect of being able to come up with the desired beam patterns and gain but operating at QBB frequencies. Further research is being carried out and results will show more reality in terms of the results of our QBB approach. The figure below illustrates the preliminary results obtained for a simple simulation carried out at QBB and RF. From the resulting beam patterns, the beam pattern coverage and lobes can be seen to be different at QBB and RF which forms the basis of the novelty in this research.



**Fig.10:** Antenna gain 5G QBB Analysis illustration

In our approach, we will perform the beamforming process at QBB. We will then do analysis and discussion of results at RF and QBB and do a comparison. The expected benefits are more efficient bandwidth usage, antenna gain , throughput amongst other factors.

**V. CONCLUSION**

This paper reviewed and looked at Antenna gain and proposes the use of Quadrature baseband (QBB) beamforming in 5G mmWave Networks compared to RF methods. Future research on the aspect of the 5G roll out will bring to the fore the aspect of exploring several beamforming hybrid methods that enhance the more efficient usage of bandwidth through optimal antenna gain enhancement. MatLab simulations will prove this benefit.

### ACKNOWLEDGMENT

This work is supported by the Zambia's Ministry of Higher Education Scholarship research Fund.

### REFERENCES

- [1] M. Kamran Khattak, S. Kahng, M. Salman Khattak, A. Rehman, C. Lee, and D. Han, "Low profile, wideband and high gain beamsteering antenna for 5G mobile communication," *2017 IEEE Antennas Propag. Soc. Int. Symp. Proc.*, vol. 2017-Janua, pp. 2575–2576, 2017.
- [2] M. Rahman *et al.*, "Integrated LTE and millimeter-wave 5g mimo antenna system for 4g/5g wireless terminals," *Sensors (Switzerland)*, vol. 20, no. 14, pp. 1–20, 2020.
- [3] K. Muzaffar, M. I. Magray, G. S. Karthikeya, and S. K. Koul, "High gain broadband vivaldi antenna for 5G applications," *Proc. 2019 21st Int. Conf. Electromagn. Adv. Appl. ICEAA 2019*, pp. 496–497, 2019.
- [4] M. K. Khattak *et al.*, "A flat, broadband and high gain beam-steering antenna for 5G communication," *2017 Int. Symp. Antennas Propagation, ISAP 2017*, vol. 2017-Janua, pp. 1–2, 2017.
- [5] T. Varum, "Planar microstrip series-fed array for 5G applications with beamforming capabilities."
- [6] C. Scarborough, K. Venugopal, A. Alkhateeb, and R. W. Heath, "Beamforming in millimeter wave systems: Prototyping and measurement results," *arXiv*, no. July, 2018.
- [7] J. Park, S. Y. Lee, Y. Kim, J. Lee, and W. Hong, "Hybrid Antenna Module Concept for 28 GHz 5G Beamsteering Cellular Devices," *2018 IEEE MTT-S Int. Microw. Work. Ser. 5G Hardw. Syst. Technol. IMWS-5G 2018*, pp. 15–17, 2018.
- [8] L. Dussopt *et al.*, "A V-Band Switched-Beam Linearly Polarized Transmit-Array Antenna for Wireless Backhaul Applications," *IEEE Trans. Antennas Propag.*, vol. 65, no. 12, pp. 6788–6793, 2017.
- [9] A. Rahimian, A. Alomainy, and Y. Alfadhl, "A Flexible Printed Millimetre-Wave Beamforming Network for WiGig and 5G Wireless Subsystems," 2016.
- [10] A. Kausar, S. Kausar, and H. Mehrpouyan, "Mathematical modeling of a smart antenna based on hybrid beam-forming technique," *2019 IEEE Int. Symp. Antennas Propag. Usn. Radio Sci. Meet. APSURSI 2019 - Proc.*, pp. 495–496, 2019.
- [11] M. Yasin and P. Akhtar, "Mathematical Model of Bessel Beamformer with Automatic Gain Control for Smart Antenna Array System," *Arab. J. Sci. Eng.*, vol. 39, no. 6, pp. 4837–4844, 2014.
- [12] L. I. Lianming, N. I. U. Xiaokang, C. Yuan, C. Linhui, Z. Tao, and C. Depeng, "The path to 5G: mmWave aspects," *J. Commun. Inf. Networks*, vol. 1, no. 2, pp. 1–18, 2016.
- [13] M. A. Hassanien, "Wideband Rotman Lens Beamforming Technique for 5G Wireless Applications," *2019 2nd Int. Conf. Comput. Appl. Inf. Secur.*, vol. 3, pp. 1–5, 2019.
- [14] M. Mezzavilla *et al.*, "End-to-End Simulation of 5G mmWave Networks," no. c, pp. 1–27, 2018.
- [15] W. Hong, K. H. Baek, and S. Ko, "Millimeter-Wave 5G Antennas for Smartphones: Overview and Experimental Demonstration," *IEEE Trans. Antennas Propag.*, vol. 65, no. 12, pp. 6250–6261, 2017.
- [16] G. Kwon, J. Y. Park, D. H. Kim, and K. C. Hwang, "Optimization of a Shared-Aperture Dual-Band Transmitting/Receiving Array Antenna for Radar Applications," *IEEE Trans. Antennas Propag.*, vol. 65, no. 12, pp. 7038–7051, 2017.
- [17] M. V. Komandla, G. Mishra, and S. K. Sharma, "Investigations on Dual Slant Polarized Cavity-Backed Massive MIMO Antenna Panel with Beamforming," *IEEE Trans. Antennas Propag.*, vol. 65, no. 12, pp. 6794–6799, 2017.