

Adaptive Control Method for Power Failure Auto Alert System with Online Monitoring of Transformer

Keerthana¹, Vahini², Matheswaran³, Suvetha⁴
^{1,2,3,4}Department of Electrical and Electronics Engineering
 Imayam College of Engineering, Kannanur

Abstract:- This paper deals with to send information about the power failure of an common area from the Electricity Board office to the consumers through wireless networks and it also disconnects the supply of consumer automatically, when the Electricity Bill is not paid within the time and also the transformer is overheated. To deliver the information about the power failure/shut down to the consumers microcontrollers is employed to create the information. Intimation about power failure is delivered to the consumers before Three hours through alarm. Relay is used to disconnect the supply of the consumer when the electricity bill is not paid within a given time period. Microcontroller is used to give intimation to the relay. Relay acts and disconnects the supply of the consumer when the transformer is overheating. If the transformer is overheated the information is also sent to the Substation. Thus the performance of overall system is verified by using Embedded codings.

Keywords:- Power Shutdown Intimation, PICM Icrocontroller, Zigbee Technology, Sensors, Transformer Monitoring, Alarm.

I. INTRODUCTION

Every moment of our life depends upon electricity. Electricity has several components and equipments helping human to transfer and regulate the distribution according to the usage. Present industry is increasingly shifting towards automation. This prototype system can be applied effectively and efficiently in an expanded dimension to fit for the requirement of industrial, research and commercial applications. Microcontroller is the heart of the device which handles all the sub devices connected across it. These are the advantages are appear here. The shutdown of power for particular area will be notified to consumers through wireless networks by using zigbee. An LED alarm is connected to the energy meter to give the notification of power failure to the consumers before 3 hours. This alarm notify shut down to the consumers. The alarm will be turn off by the consumers after receive notification. It also turn off automatically after 30 minutes. The temperature of the distribution transformer is monitored continuously by using temperature sensor and the temperature level of the distribution transformer is monitored by using PIC microcontroller. If the temperature of

distribution transformer exceeds above 35degree Celsius it will sensed by PIC microcontroller and the supply of the consumer is disconnected by using 12V DC Relay. The information about overheating is also send to substation. Electricity Bill payment of consumers is monitoring and disconnects the supply of Consumers who are not pay their Electricity Bill by using 12V DC relay. The relay receive intimation from PIC microcontroller and disconnect the supply.

II. REVIEW OF TRANSMISSION SYSTEM

The transmission system plays significant roles in the supplying of power to the consumers uninterruptedly. Monitoring of these systems is very essential if supplying of healthy power to the consumers is to be achieved.

Incorporated in the transmission system is the protective system which helps in detecting the abnormal or fault signals. The protective relays in the protective system then isolate the faulted part from the entire system, ensuring minimal equipment damage and disturbance. Fault analysis is an essential concern in power system engineering in order to isolate faults quickly and ensure power supply is restored at the shortest possible time [7]. Power demand has resulted in higher line current loads, still bearing in mind that operator sare limited by the system and line capacity [8]. Overloading the system will lead to overheating of the system insulation which ultimately result into the system failure[9].Peripheral Interface Controller (PIC).aids the improvement in power quality, ensuring a continuous and reliable supply of power to loads.

2.1 Faults in power system

Basically, faults can exist in four forms: they include line-to-line fault, double line-to-ground fault, single line-to-ground fault and three phase fault .Different magnitude of fault current can result from each of these types of faults. Short circuits damage can be prevented by employing the use of circuit breakers, relays, or other protection as they help to disconnect the power in response to high current[10].

2.2 Zigbee technology

The mission of the Zigbee Working Group is to bring about the existence of a broad range of interoperable consumer devices by establishing open industry specifications for

unlicensed, untethered peripheral, control and entertainment devices requiring the lowest cost and lowest power consumption communications between compliant devices anywhere in and around the home.

The Zigbee specification is a combination of HomeRF Lite and the 802.15.4 specification. The spec operates in the 2.4GHz (ISM) radio band - the same band as 802.11b standard, Bluetooth, microwaves and some other devices. It is capable of connecting 255 devices per network. The specification supports data transmission rates of up to 250 Kbps at a range of up to 30 meters. ZigBee's technology is slower than 802.11b (11 Mbps) and Bluetooth (1 Mbps) but it consumes significantly less power.

2.3 Alert system using Buzzer

A **buzzer** or **beeper** is a signalling device, usually electronic, typically used in automobiles, household appliances such as a microwave oven, or game shows. It most commonly consists of a number of switches or sensors connected to a control unit that determines if and which button was pushed or a preset time has lapsed, and usually illuminates a light on the appropriate button or control panel, and sounds a warning in the form of a continuous or intermittent buzzing or beeping sound. Initially this device was based on an electromechanical system which was identical to an electric bell without the metal gong (which makes the ringing noise). Often these units were anchored to a wall or ceiling and used the ceiling or wall as a sounding board. Another implementation with some AC-connected devices was to implement a circuit to make the AC current

into a noise loud enough to drive a loudspeaker and hook this circuit up to a cheap 8-ohm speaker. Nowadays, it is more popular to use a ceramic-based piezoelectric sounder like a Sonalert which makes a high-pitched tone. Usually these were hooked up to "driver" circuits which varied the pitch of the sound or pulsed the sound on and off.

III. METHODOLOGY

The system shown in fig 1, is used to monitor the transformer using Peripheral Interface Controller and disconnects the supply of consumer when the transformer is overheated i.e) the temperature of the transformer exceeds 35 degree Celsius and give intimation about overheating of transformer. It also disconnects the supply of consumers when the Electricity Bill is not paid with in the time. The system also used to intimate about power shut down to the consumers before Three hours of power Shut down.

Distribution transformer is connected to the temperature sensor to monitor the temperature of distribution transformer and it is connected to the PIC microcontroller. Relay on consumer side is controlled by PIC microcontroller. Alarm is used to give intimation about power shut down to the consumers. The relay employed in this paper is 12V DC Relay. The Relay is also used to disconnect the supply of consumers when Electricity Bill is not paid by the consumers. Zigbee is used to transmit the information from substation to the consumers. Real time clock is used to give accurate timing to the consumer side.

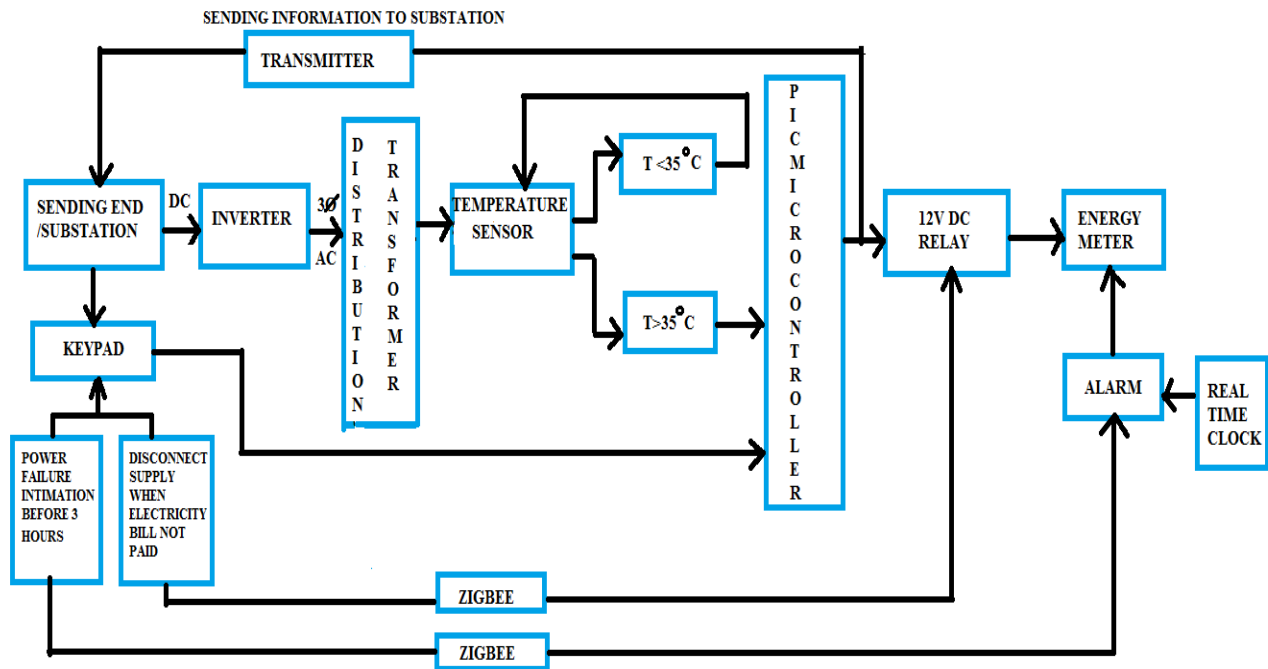

Figure 1 Block diagram of the Auto alert and disconnecting system

The 5V regulated DC power supply, shown in Figure 2, was used to power the system components.

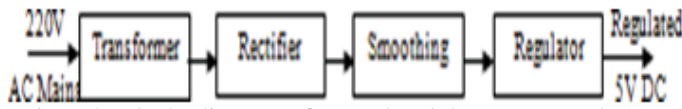

Figure2. Block diagram of a regulated dc power supply system

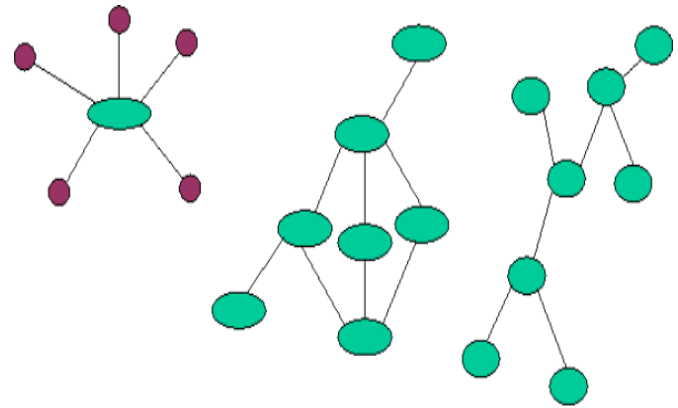

Figure 4 Block diagram of Zigbee

Timer/counter	I/O Ports	Program memory
Data Memory	micro processor	ADC, etc...

Figure 3 Block diagram of typical microcontroller

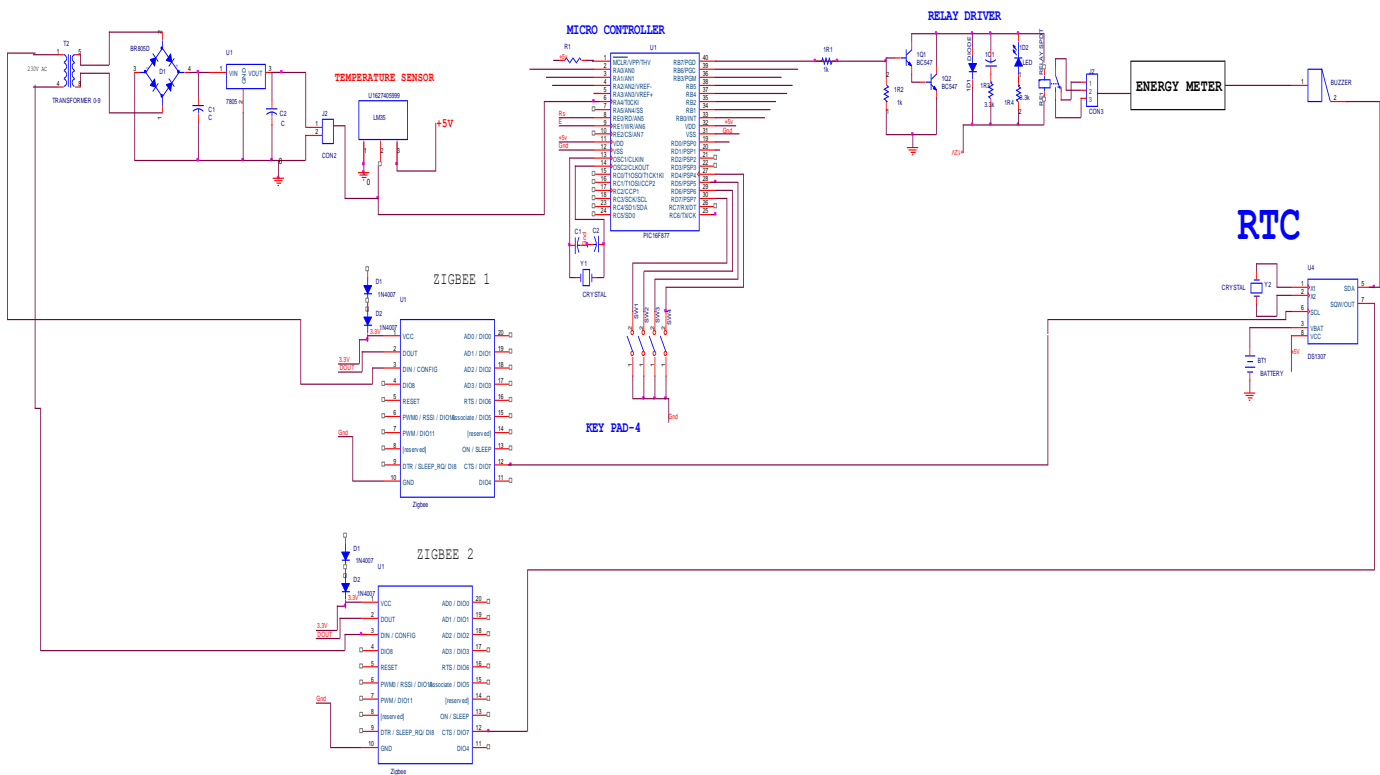

Figure 5 is the complete system circuit diagram

Sending end is used to supply the Direct Current to the Inverter. Inverter is employed to convert Direct current which is the output of sending end substation to Three phase Alternating Current. Distribution Transformer is used to distribute power to the consumers by step up or step down the supply voltage (11 KV to 230V) and it may be overheated due to overloading and some unexpected reasons. So the temperature of the transformer is monitored. Temperature

Sensor is employed to monitor the temperature of the transformer. If the temperature of the distribution transformers exceeds 35 degree celsius it gives the intimation to PIC microcontroller. PIC Microcontroller is employed here to perform three operations. To receive signal from temperature sensor and gives intimation to 12V DC relay to disconnect the supply of consumers and also gives intimation to substation about overheating by using transmitter. To send the

information about power shut down to the consumers by using Zigbee. To disconnect the supply of consumers when Electricity Bill is not Paid with in the time by using Zigbee. 12V DC Relay is used to disconnect the Supply of consumers, When transformer is overheated and also the Electricity Bill is not paid by the consumers. Zigbee is used to transmit the information from substation to the consumers. Alarm is used to give intimation about power shut down to the consumers before Three hours. Transmitter is used to transfer information from PIC Microcontroller to the substation about transformer overheating. Keypad is connected to Microcontroller to input the shut down date and also used to input the information about the consumers who are not paid their Electricity Bill.

IV. HARDWARE MODULE

Eb Section



Home section



V. CONCLUSION

Here, in this project we have designed an adaptive control method for online monitoring of transformer, intimation about power shut down to the consumers and disconnection of supply of consumers when transformer is overheated and Electricity Bill is not Paid in a given time period by the consumers. The implemented system mainly concentrates on the distribution system. It provides the way to detect the fault on transformer and also disconnect the supply of consumers immediately. The system continuously monitors the temperature of the transformer and helps to detect the fault at the appropriate time and hence reduce the wastage of electricity and also protects the distribution side. Automatic monitoring ,analyzing and recording is done by PIC microcontrollers. The project has continuous monitoring system and transfer of information are held via zigbee technology. The implementation of the system will helps the substation to monitor the transformer through wireless system and disconnect the supply of consumers who are not paid their

Electricity Bill. It also helps to substation to give intimation about power shut down to the consumers. This system will help to consumer to know about power shut down time before Three hours of power shut down and the supply of consumer automatically gets disconnected when the transformer gets overheated.

REFERENCES

- [1]. H.LuandL.Yao“Design and Implement of Distribution Transformer Outage Detection System”National Science Council of the Republic of China, NSC94-2213-E-027-055.2007.
- [2]. Prof.M.S.Sujathaetal.“On-line Monitoring and Analysis of Faults In Transmission And Distribution Lines Using GSM Technique”, November2011
- [3]. J.G.S.daSilvaa,P.C.G.da S.Vellascob,S.A.L.deAndradeb, M.I.R. de Oliveirab, “Structural assessment of current steel design models for transmission and telecommunication towers”,Journal of Constructional Steel Research61:1108-1134,2005.
- [4]. N.Laneman,D.Tse,andG.Wornell,“Cooperative diversity in wireless networks:Efficient protocol sand outage behavior,” *IEEE Trans. Inf. Theory*, vol. 50,pp. 3062–3080,Dec.2004.
- [5]. A.Sendonaris,E.Erkip,andB.Aazhang,“User cooperation diversity—PartIandII,” *IEEETrans. Commun.*, pp.1927 1948, Nov. 2003.
- [6]. I.Hammerström,M.Kuhn,andA.Wittneben,“Cooperativ e diversity by relay phase rotations in blockfading environments,” in *Proc. IEEE Workshop Signal Process.AdvancesWireless Commun.*,Jul.2004,pp.293–297.
- [7]. R. U. Nabar, O. Oyman, H. Bölcskei, and A.Paulraj,“Capacity scaling laws in MIMO wireless networks,” in *Proc.Allerton Conf. Commun.,Control and Comp.*, Oct. 2003, pp.378–389.
- [8]. A.WittnebenandB.Rankov,“Distributed antenna systems and line arrelaying for gigabit MIMO wireless”.
- [9]. H. Arleving, “Ways to cut power generator maintenance”the journal,(2013).
- [10]. Jawwad Sadiq Ayon et al. “Remote Monitoring of aPower Station (Voltage Monitoring) Using GSM”, November2014.
- [11]. M. Gebhardt, F. Weinmann, and K. Dostert, “Physicalandregulatory constraintsforcommunication overthepower supply grid,” *IEEE Commun. Mag.*, vol. 41, no. 5,May2003.
- [12]. Y. Jaganmohan Reddy, Y. V. Pavan Kumar, K. PadmaRaju, A. Ramsesh, “PLC Based Energy Management and Control Design for an Alternative Energy Power Systemwith Improved Power Quality”, *International Journal of Engineering Research and Applications*,vol.3,no.3,(2013).
- [13]. Kurt Josef Ferreira“Fault Location for Power Transmission Systems Using Magnetic Field Sensing Coils”ECE Department of Worcester Polytechnic Institute,April 2007
- [14]. K. S. Ahn “Digital Controller of a Diesel Generator using an Embedded System”*International Journal of Information Processing Systems*,vol.2,no.3,(2006).
- [15]. Vinod Gupta, U. C. Trivedi, N. J. Buch, “Solid State Electronic Fault Current Limiter to Limit the Fault Current in Power System”, *Electrical Research & Development Association*,adodara-390010, NPEC-2010.
- [16]. S. Vimalraj, R. B. Gausalya, “GSM Based Controlled Switching Circuit between Supply Mains and Captive Power Plant”,*International Journal of Computational Engineering Research*,vol,03,no. 4,(2013).
- [17]. Chandra shekar, “Transmission Line Fault Detection &Indication through GSM”, *International Journal of Recent Advancesin Engineering & Technology (IJRAET)*,Volume-2, Issue-5,2014.
- [18]. Constantin Daniel Oancea,” GSM Infrastructure Used for Data Transmission”, 7th International Symposium on Advanced Topics in Electrical Engineering (ATEE), 2011May12-14, Page(s): 1–4.
- [19]. Y.J.Lin,“A power line Communication Network Infrastructure for the Smart Home”,*IEEE Wireless Communications*, December,2002.
- [20]. *Proc. IEEE Special Issue on Gigabit Wireless*, vol. 92,no. 2,Feb.2004