

IoT Based Smart Delivering Robot for Isolation Ward

J. Luke Carishma*, S. Pavithra*, S. Mukunthan*, M. Gayathri*

*Assistant Professor, Dhanalakshmi Srinivasan College of Engineering, Coimbatore

Abstract:- The pandemic covid-19 have brought a vast change to the world and made us distant socializing rather than social distancing. The medical sectors are facing a crucial sitch on this. Health care professionals are petrified of their own lives. Many are isolated day by day to the hospitals and the only way to overcome this disease is to avoid the interconnections between the people even in hospitals. Moreover an iot based remote controlled robot for navigating ,delivering food and drugs can limit the interactions of medical professionals to patients. Ensuring the safety and low expansion of covid-19 ,the robot can be controlled anywhere from the hospital. And multiple sensors can leverage many tasks without contacting patients including measuring the oxygen level. The navigation of the system is done by Ultrasonic Sensor , camera(ESP-32) and motors(DC-300rpm-12V Centre shaft DC geared) , it is directed by android application (controller version 1.0)

Keywords:- Robot , Sensor, Ultrasonic Sensor , Camera , Android Application.

I. INTRODUCTION

IoT plays an important role in the technology development stream. Simply IoT means interconnection of object that are able to collect and transfer data over a wireless network. By looking to the current scenario we all know that covid19 exposed in the world and affected people are advised to quarantine for 14 days [1]. The connection of many devices can be done using (IoT) through internet. The interoperability of vehicle ventilation systems is done using NodeMCU, which is a microcontroller to monitor and control sensors . It can be controlled by android application [2].

The internet of things is being used in several applications at an industrial level. The main feature of this is it does not require human-to-human interactions. But the humanoid robots have certain chances to be directed by humans and this can be restrained usind android application [3].The Robots can be used as social workers.[4] The outbreak of covid19 has affected 212 countries and territories across the globe. During this , health care professionals are in the front line of the battle. And they are at high risk of infection. We are in charge of securing their lives too. Therefore uncovering possible ways to lower and control the disease becomes a sore problem to solve [5]. Coronavirus a dangerous pandemic in the world wide have outstretched upto 72.5 million peoples and nearly1.62 million people have died. By considering the menacing situation of this disease the whole world is recommended to wear mask and keep social distancing. However the spreading of disease increases day by day. To avoid such spreading IEEE professionals

discovered a robot [6]. Since the eruption of covid19 in Dec 2019 , many hospitals and medical workers are petrified to trat the affected people . To alleviate worn out medical workers from the pandemic situation , some Chinese hospitals developed an intelligent robot. By using this robot, we can reduce the direct contact between the medical workers and the patients [7]. The covid19 pandemic will have a long- lasting impacy on the entire world. Scientists already started research programs and the educators are changing the way that the next generation of researchers. These changes are impactful to the human-robot interaction. Yet this research performed in the coming year will be changed in different ways. Based on thus producwd an moving robot to reduce the spreading [8].

The covid19 pandemic situations the robotics in healthcare and allied areas maintain a special concern relating and control of spread. The utilization of robots to minimize persons contact and support in hospital management. The robotics utilization minimizing the life threat to medical staff and doctors [9]. In hospice, drug distribution or drug delivery is a key task executed even in a pandemic situation or in usual state. In order to do the duty , the robot can turn down the direct contact among healthcare providers and sufferers [10]. To elaborate and expand the performance of robots can be carried out by the proper allocation of the piece of work. This can be accomplished by setting the robot which can do more than one role rather one at a time [11].

II. AN OVERVIEW OF ROBOT TECHNOLOGY

A. Delivery of medicines and essentials

In the current crisis the risk of the medical staff and burden paved by them can be reduced by functioning of robots. The essential things needed for the patients can be delivered without contacting them manually. The space provided in robot to carry medicines and food items to a specific patient can control this virus from spreading.

B. Robot System

The robot is designed with the low cost Rigid form board material body having 40 cm height, 35 cm width and 7 cm wheel diameter. The motion mechanism is done using DC motors, which is connected to the motor drivers. And it is electronically controlled using mobile application which controls the whole motion of robot. The ultrasonic Sensors are used as the proximity sensor which detects the backward distance. If an obstacle is detected, „obstacle detected“ is displayed in the mobile application.

C. Considerations for designing Robot

While designing the robot following parameters are met.

Dimensions	The dimensions and size needed for the robot was finalized.
Sketches	Two dimensional sketch for the robot was created
Model	Three dimensional model was created from the 2D model
Appearance	The components were fixed to the correct places, which gives a good appearance.

Table.1

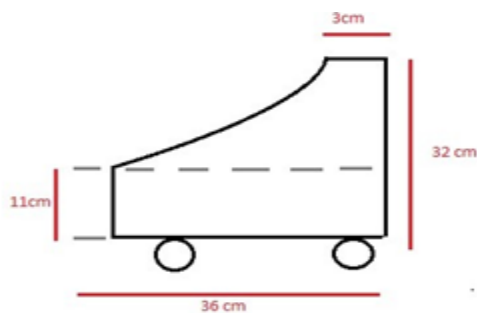

Fig.1 Side view in 2 Dimension

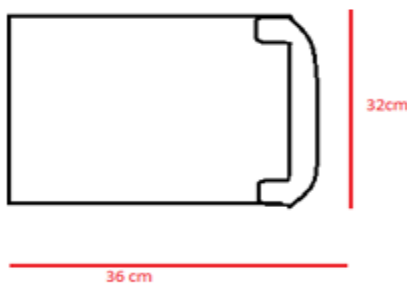

Fig.2 Top View in 2 Dimension

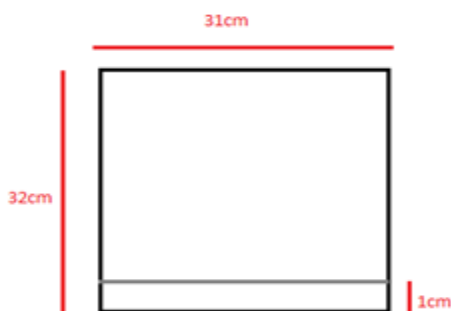

Fig.3 Back view in 2 Dimension

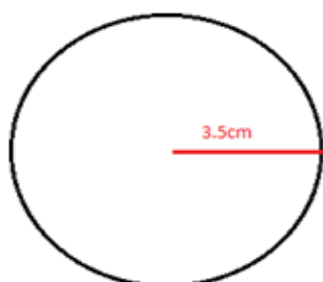

Fig.4 wheel alignment in 2 Dimension

III. DESIGN METHODOLOGY

The system which we designed consist of three major functions, such as measuring the oxygen level of the patient, viewing the patient through camera, delievering the sufficient things to the patient. The design of hardware and software is detailed in the section. The Fig.5 indicates block schematic diagram of our system and Fig.6 indicates the operational flow diagram of our system. The rate oh heart and SpO2 is measured by placing the finger tips in pulse oximeter. The two rates thus measured can be controlled by Arduino Nano board, and the information is send to the Node MCU.

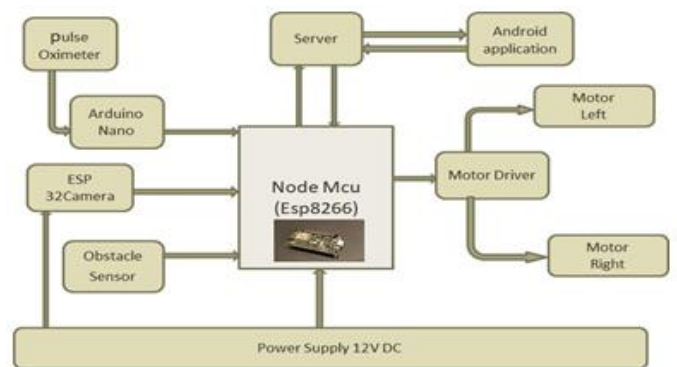

Fig.5 Block schematic diagram

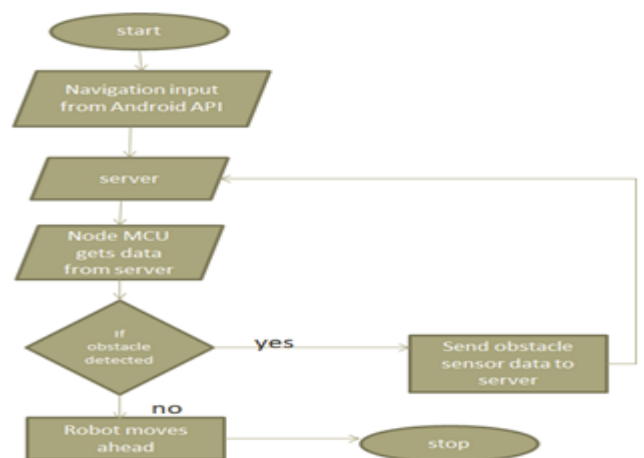

Fig.6 Operational flow diagram

The Android application is used as the whole control of movement in robot.As the user moves the cursor in the application , the navigation input is send to server. And server sends data to NodeMCU. The front and side view can be adjusted through application and proximity sensor detects the backside obstacle if present.

A. Pulse oximeter

The Oxygen level of a human body can be measured using a device called Pulse oximeter. Lower level of oxygen in the body is a symptom for covid-19 patients .The oximeter used in robot can scrutinize the patient's oxygen level. The normal people have an oxygen level of 95% or more. The SPO2 level in oximeter indicates the oxygen level.

B. NodeMCU

The NodeMCU is an open source IoT development board with having a unique feature such as inbuilt WiFi. This board can be connected to a WiFi network and also can setup its own network. It uses 128 KB RAM and 4MB flash memory. The power required to operate the ESP8266 is 3V to 3.6V. The LDO voltage regulator keeps the voltage steady at 3.6V. The ESP8266 NodeMCU has two buttons, one located on top left corner is Reset button and other on bottom left corner is the download button copied to ABM URL's and press OK to Enter. From the Tools menu search and select ESP8266. Choose desired board to upload the code.

C. Mobile Application

An android application developed by the user is used to control and navigate the robot. The APK file named controller version 1.0 having file size of 2.3 MB (2,411,724 bytes).

D. Arduino IDE

IV. CIRCUIT DESIGN

The Fig.9 indicates the circuit diagram representation of robot. The main board used in the design is NodeMCU esp8266 microprocessor. To operate the system a 12V battery power supply is used, which is converted to 5V using IC7805 DC converter. The motor used to rotate wheels are DC motors. The motor driver LM298N is used for the protection of motors from burning. Input pins from motor driver is connected to datapins (D5,D6,D7,D8). Pulse sensor MAX30100 is connected to analog pins (A4,A5) of Arduino nano. And digital outputs from Arduino nano is sent to the digital output pins of NodeMCU. Esp 32 CAM is programmed and connected to the server. The Echo and Trig pins of Ultrasonic Sensor is connected to digital pins (D2,D3) as input.

The Arduino Integrated Development Environment (IDE) is the open source software used to write and upload programs to the arduino compatible boards. It supports the languages C and C++ by utilizing special rules of code structuring. The process followed by selecting the preferences from the file menu and overall connection builds the smart delivering robot.

Node MCU Pinout – ESP8266 12E

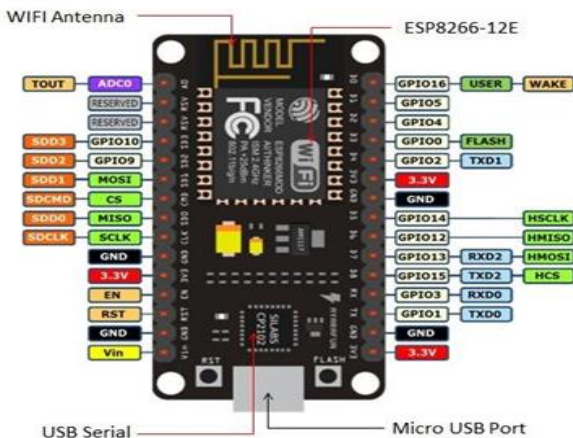

Fig.7. NodeMCU pindiagram

E. Arduino Nano

The Arduino Nano is a small board which can work with a USB. Here this board is used to take two values from the Pulse Oximeter.



Fig.8. Preview of APK

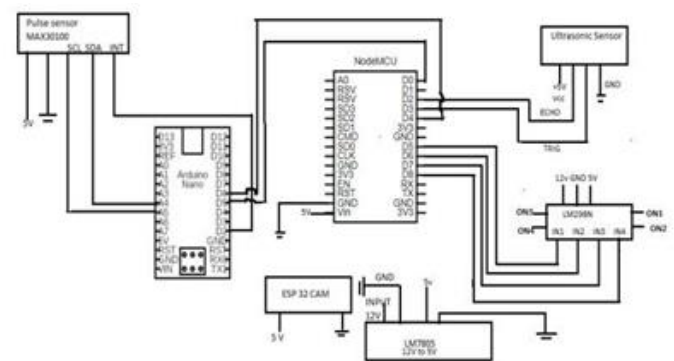

Fig.9. Circuit Diagram

V. SIMULATION RESULTS AND DISCUSSION

A. Observation on Mobile Application

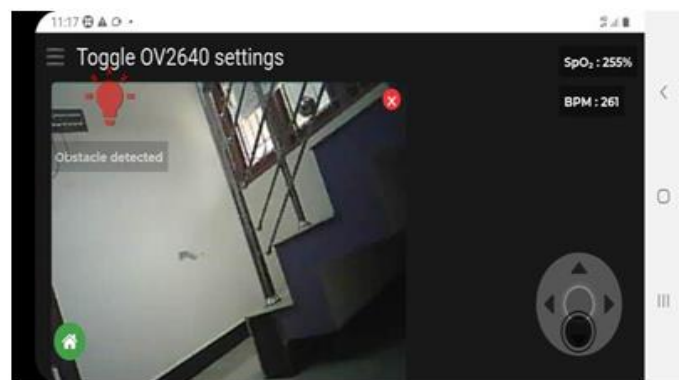

Fig.10. Complete output from APK

The patients, Beats per Minute of heart and SpO₂ level is displayed in the mobile application. Since the camera is facing in one direction an extra sensor is fixed in backside of camera to detect the obstacle. The directions can be

controlled using the arrows. Since this a prototype model it can take a maximum weight of 1kg.

V. CODING

https://docs.google.com/document/d/1ZmyAQovkP_9iXoKvYscwREdV02LpHriE8TAq4xPIIA/edit?usp=sharing
<https://docs.google.com/document/d/1Ri4Au3BtoX-8gK6y9O6aqbZmdf8cdd-bPanPIAgu3SQ/edit?usp=sharing>

VI. CONCLUSION

The covid has taken whole parts of the world, all age groups. It is our need to fight the battle against the covid-19 virus. As a support to the health care workers, the smart delivering robot is specially designed robot for isolation ward to deliver food, medicine and other essentials. The control and navigation through the android application developed by user accomplish tasks of robot. The robot can lower person to person interaction which bring down risk as well as spreading of infection. Instead of health care professionals, robot can execute tasks under decontaminated state. In addition, an Oximeter is deployed inside the robot to assess the oxygen level in patients body. With this implementation, the disease can be lowered. This model what we implemented is a prototype model. More space can be provided for the robot to give more services to patients. And more type of sensors can be added.

REFERENCES

- [1]. Mohammad_Nasajpour, Seyedamin Pouriyeh, Reza M. Parizi, Mohsen Dorodchi, Maria Valero, Hamid R. Arabnia, "Internet of Things for Current COVID-19 and Future Pandemics: an Exploratory Study" Journal of healthcare informatics Research, 12 Nov 2020.
- [2]. Amirun Murtaza Abd Jalil, Roslina Mohamad, Nuzli Mohamad Anas, Murizah Kassim, Saiful Izwan Suliman, "Implementation of vehicle ventilation system using NodeMCU ESP8266 for remote monitoring" Bulletin of Electrical Engineering and Informatics Vol. 10, No. 1, February 2021.
- [3]. Robin R. Murphy, Vignesh Babu Manjunath Gandudi, Justin Adams, "Applications of Robots for COVID-19 Response"[cS.Ro], 16 Aug 2020.
- [4]. Yamada, S., Nomura, T., & Kanda, T. "Healthcare support by a Humanoid Robot. In 2019 14th ACM/IEEE International Conference on Human-Robot Interaction (HRI) (pp. 1–2)". Daegu, Korea (South), 2019.
- [5]. Geng Yang, Honghao LV, Zhiyu Zang, Liu Yang, Jia Deng, Siqi You, Juan Du, Huayong Yang "Keep Healthcare Workers Safe: Application of Teleoperated Robot in Isolation Ward for COVID-19 Prevention and Control", Chinese Journal Mech Eng, Nature public Health care collection, June 9 2020.
- [6]. Yang Shed, Dejun Guo, Fei Long, Luis A. Mateos, Houzhu Ding, Zhen Xiu, Randall B. Hellman, Adam King, Shixun Chen, Chengkung Zhang, And Huan Tan, "Robots Under COVID-19 Pandemic: A Comprehensive Survey" IEEE Access, volume 9, 18 Dec 2020.
- [7]. Meijun shu, jiarui Lu, "Health digital technology in COVID-19 pandemic: experience from China", BMJ innovations, 25 Aug 2020.
- [8]. David Feil-seifer, Kerstin S. Haring, Silvia Rossi, Alan R. Wagner, Yom Williams, "Where to Next? The Impact of COVID-19 on Human-Robot Interaction Research" ACM Trans. Hum.-Robot Interact. 10, 1, Article 1 (June 2020), 7 pages.
- [9]. Zeashan Hameed Khan, Afifa Siddique, Chang Won Lee, "Robotics Utilization for Healthcare Digitization in Global COVID-19 Management", International Journal on Environmental Research and Public Health, 28 May 2020.
- [10]. Maria Pia Fanti, Agostino Marcello Mangini, Michele Roccotelli, Bartolomeo Silvestri, "Hospital Drug Distribution with Autonomous Robot vehicles", 2020 16th IEEE International Conference on Automation Science and Engineering (CASE), August 20-21, 2020, Online Zoom Meeting.
- [11]. Seohyun Jeon, Jaeyeon Lee "Vehicle routing problem with pickup and delivery of multiple robots for hospital logistics", 2016 16th International conference on control automation and Systems (ICCAS), 26 January 2017
- [12]. Georgios Angelopoulos, Georgios Theodoros Kalampokis, Minas Dasygenis, "An Internet of Things humanoid robot teleoperated by an open source Android application" IEEE 2017 Panhellenic conference on Electronics and Telecommunications (PANCET), 18 Jan 2018.
- [13]. Kirtikumar.C, Ashish.B, Dipak V. Dhangar, & Vivek.C, "Importance and use of pulse oximeter in COVID-19 pandemic: general factors affecting the sensitivity of pulse oximeter", 27 Nov 2020.
- [14]. Valentina Quaresima and Marco Ferrari, "COVID-19: efficacy of prehospital pulse oximetry for early detection of silent hypoxemia, Quaresima and Ferrari Critical Care", 13 August 2020.
- [15]. Vogan, A. A., Alnajjar, F., Gochoo, M., & Khalid, S. "Robots, AI, and cognitive training in an era of mass age-related cognitive decline: a systematic review". IEEE Access, 8, 18284–18304, 2020.
- [16]. Meia Chita-Tegmark & Matthias Scheutz, "Assistive Robots for the Social Management of Health: A Framework for Robot Design and Human-Robot Interaction Research" International Journal of Social Robotics, 02 March 2020.
- [17]. Liao, W., Nagai, K., & Wang, J. "An evaluation method of electromagnetic interference on bio-sensor used for wearable robot control". IEEE Transactions on Electromagnetic Compatibility, 62(1), 36–42, 2020.
- [18]. Alotaibi, M., & Yamin, "Role of robots in healthcare management. In 6th International Conference on Computing for Sustainable Global Development (INDIACom) (pp. 1311–1314)". New Delhi, India, 2019.

- [19]. McGinn, C., Bourke, E., Murtagh, A., Donovan, C., & Cullinan, M. F. "Meeting stevie: perceptions of a socially assistive robot by residents and staff in a long-term care facility. In 2019 14th ACM/IEEE International Conference on Human-Robot Interaction (HRI) (pp. 602–603)". Daegu, Korea (South),2019.
- [20]. Chen, M., & Chen, K. "Applying a stable dynamic walking mode of humanoid robot based on adaptive fuzzy control. In IEEE Eurasia Conference on Biomedical Engineering, Healthcare and Sustainability (ECBIOS) (pp. 177–180)"Okinawa, Japan,2019.
- [21]. Varshney, V., Kumar, A., Saxena, T., Jha, P., & Tiwari,
- [22]. M. N. "Design and development of intellectual robotic arm. In 6th International Conference on Computing for Sustainable Global Development (INDIACom) (pp. 984–987)". New Delhi, India,2019.
- [23]. Azeta, J., Bolu, C., Abioye, A., & Oyawale, F. "A review on humanoid robotics in healthcare". MATEC Web of Conferences, 153,2018.
- [24]. Pang, V., Yang, G., Khedri, R., & Zhang,
- [25]. Y. "Introduction to the special section: convergence of automation technology, biomedical engineering, and health informatics toward the healthcare 4.0". IEEE Reviews in Biomedical Engineering, 11, 249–259,2018.
- [26]. Xu, J., Bryant, D. G., & Howard, "Would you trust a robot therapist? Validating the equivalency of trust in human-robot healthcare scenarios". 27th IEEE International Symposium on Robot and Human Interactive Communication (RO-MAN) (pp. 442–447). Nanjing,2018.
- [27]. Han, J., Kang, H., Kwon, G. H. "Understanding the service scape of nurse assistive robot: the perspective of healthcare service experience". In 14th International Conference on Ubiquitous Robots and Ambient Intelligence (URAI) (pp. 644–649). Jeju,2017.
- [28]. Breazeal, C. "Social robots: from research to commercialization". In 2017 12th ACM/IEEE International Conference on Human-Robot Interaction HRI (pp. 1–1), Vienna,2017.