

Study the Mechanical Behaviour of Al 7075 with Silicon Nitride by Computer Analysis & Stir Casting

Fazludheen Chemmala^{*1}

^{*1} Prof., Head of the Department of Mechanical Engineering,
Eranad Knowledge City Technical Campus, Cherukkulam,
Manjeri, Kerala, India.

Anoop M^{*2}, Sinesh P^{*2}, Shamla Pc^{*2},
Abdul Rauoof Ek^{*2}

^{*2} Students of Department of Mechanical Engineering,
Eranad Knowledge City Technical Campus, Cherukkulam,
Manjeri, Kerala, India

Abstract:- This paper is a study about the aluminium series 7075. 7075 aluminium alloy's composition roughly includes 5.6–6.1% zinc, 2.1–2.5% magnesium, 1.2–1.6% copper, and less than a half percentage of silicon, iron, manganese, titanium, chromium, and other metals. By this study we trying to improve the properties of AL7075 to the properties of 5 series. We can apply this to Marian and Aerospace applications because of the improved mechanical properties. By the addition of silicon nitride in different compositions (2%, 4%, 6%) to the Al7075 and we cast it and testing it. This theme developed from the studies of deferent AL material and its behaviour. We can see that the addition of a different compound to the AL helps to improve its properties and the improved materials use in different modes.

Keywords:- al7075, Silicon Nirtride, Ansys, Stir Casting.

I. INTRODUCTION

Aluminum alloys are alloy which is mainly used in engineering structures and part with good properties. Aluminum alloy is light in weight, strong, corrosion-resistant and cheaper. Aluminum alloy is widely used in industries like automobile, aerospace, marine. Aluminum alloys are heat treatable to improve their properties. Casting, thermo mechanical and heat treatment can be affecting the properties of aluminum alloy.

Al-7xxx series also known as Al-Zn alloy due to more quantity of zinc. Al-7xxx series is the strongest aluminum series but low in fatigue property. It has poor corrosion resistance for exfoliation corrosion and stress cracking corrosion. So it is difficult to use in welded structure due to its corrosion resistance. Al-7xxx series widely used in aerospace due to its light weight and more availability.

Al-7075 has a lot of applications as it is more powerful. Aluminum 7075 is used as an alloy matrix material and is manufactured using a combination of single and multiple reinforcing particles like SiC, Al₂O₃, Gr, TiO₂, TiB₂, B₄C, fly ash, bagasse ash, coconut ash etc. By adding these reinforcements to Al 7075 there is an increase in mechanical properties, tribological properties etc. So it can be used in more applications. Al 7075 has excellent mechanical properties and fatigue resistance. Al 7075 is used in many applications due to its high specific strength, mainly

automotive and aviation. Al 7075 is widely used in mould tool manufacturing due to its high strength, low density, thermal properties, and its ability to be highly polished. This report is about to change in mechanical properties Al 7075 while adding silicon nitrate has reinforcement. The experiment is done in adding reinforcement as silicon nitrate with varying weight percentage of 2%, 4% and 6%. The ansys is made in computer analysis and we concluded that 6% of silicon nitrate will give better result in mechanical properties. We choose silicon nitrate because of it is a hard ceramic particle so there will be a good change in mechanical properties so it can use in further application. We have observed that until now there has been no work done on Al 7075 and silicon nitride. From the literature reviews, we concluded that to do a project on Al 7075 reinforced with Silicon nitride varying % wt of 2%, 4%, 6%. The tests carried on the specimen are Hardness test, Tensile test, Impact test, flexural test, SEM.

1. Aluminium 7075

7075 Aluminum is a 7xxx alloy commonly used for aircraft applications, mobile devices and other high-pressure parts because it is one of the highest aluminium alloys available. It has an excellent weight-to-strength ratio and is ideal for high-pressure parts. In aniline conditions, this grade can be formed and heat-treated if necessary. It can be welded in place or a flash (not recommended for arc and gas)

1.1. Physical properties of 7075 aluminum

7075 aluminium is composed of 90.0% Al, 5.6% Zn, 2.5% Mg, 0.23%Cr, and 1.6% Cu, though these numbers nominally fluctuate depending upon manufacturing factors. Its density is 2.81 g/cm³ (0.102 lb/in³), which is relatively light for a metal. 7075 Aluminum alloy is the strongest aluminium alloy available, making it valuable under high-pressure conditions. The copper content of 7075 aluminium increases the risk of damage, but this sacrifice is required to produce such a strong but functional material.

7075 Aluminum alloy be further can be improved using a process known as heat treatment, sometimes referred to as "tempering". This method uses high heat (300-500oC) to strengthen the overall mechanical properties of the metal and can make or break a material.

1.2. Mechanical properties of Al 7075

Mechanical properties	Matric value
Ultimate tensile strength	572 MPa
Tensile yield strength	503MPa
Shear strength	331MPa
Fatigue strength	159MPa
Modulus of elasticity	71.7GPa
Shear modulus	26.9GPa

II. METHODS

To create the new material we decided to use two methods 1. Computer analysis 2. Physical casting. With the help of the computer method, we can reduce the cost, time material loss etc... by the physical casting, we get accurate and real results.

1.3. Computer Analysis

Let us consider adding silicon nitrite with aluminium alloy 7075, we adding silicon nitrite with aluminium alloy 7075 in various percentages, that is silicon nitrite 2% + al 7075 98%, silicon nitrite 4% + al 7075 96% and silicon nitrite 6% + al 7075 94%. We need to select the better material composition of silicon nitride and aluminium alloy 7075. If we intend to do all this analysis conventionally without using software we have to do all the experiment repeatedly until we get the perfect design, doing these many repeated test practical before manufacturing our work too costly and also too time-consuming, so we use finite element analysis software like ANSYS. Then we are choosing the better material composition of silicon nitride and aluminium alloy 7075 by using Ansys software.

Here is the result of what we did with the Ansys software,

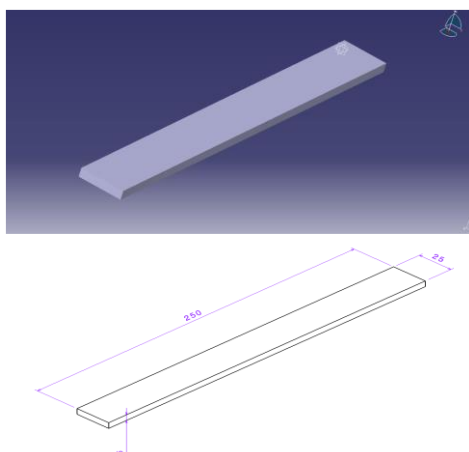

Test specimen

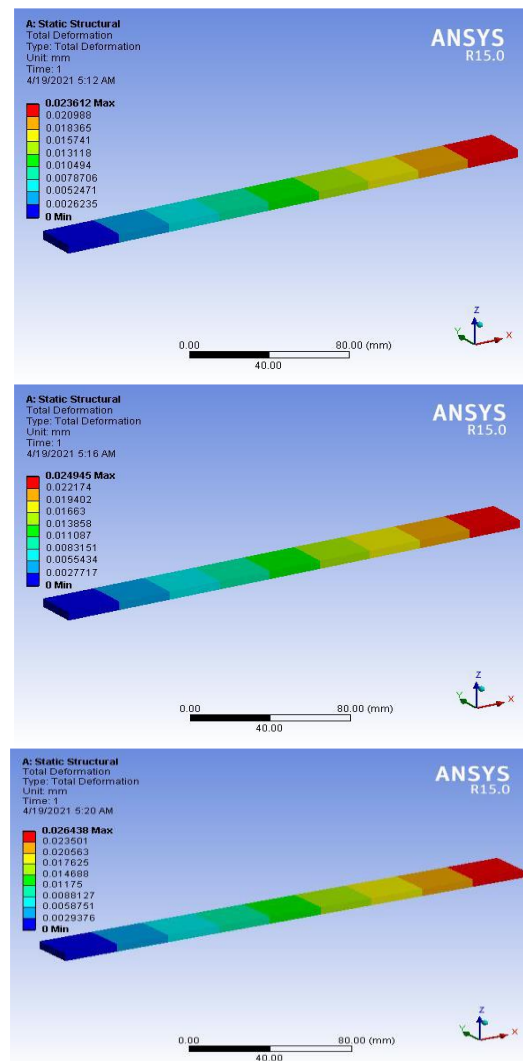

Al 7075 94% + Silicon nitride 6 % Al 7075 96% + Silicon nitride 4 % Al 7075 98% + Silicon nitride 2 %

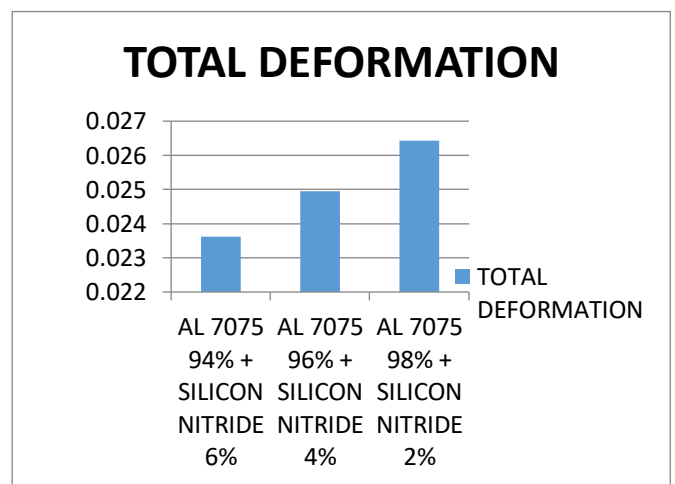

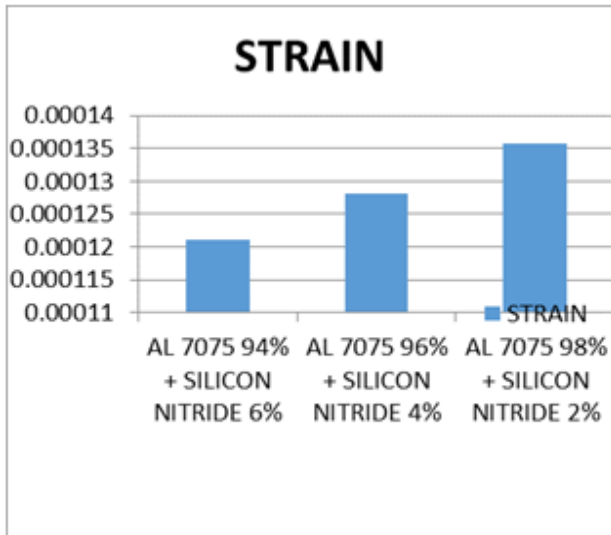

III. RESULT

The results obtained are as discussed below;

Mechanical properties	Matric value
Ultimate tensile strength	596 MPa
Tensile yield strength	525MPa
Shear strength	352MPa
Fatigue strength	175MPa
Modulus of elasticity	76.2GPa
Shear modulus	32.7GPa

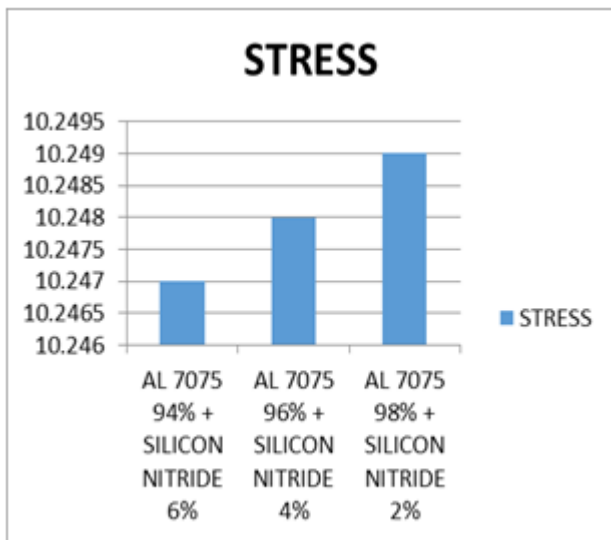

SEM result

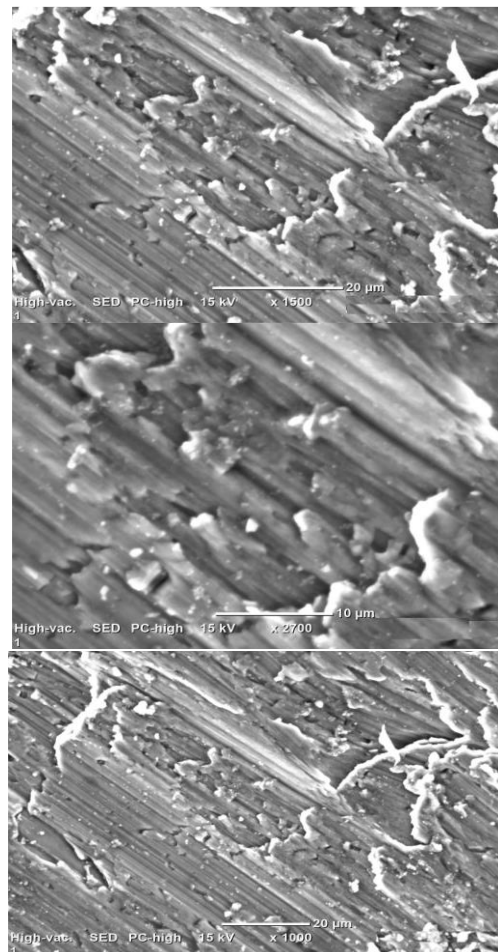

Stir casting

Aluminium alloy can be cast in different methods like squeeze casting, spray casting, powder metallurgy, stir casting etc. Stir casting is the most commonly seen casting due to its low cost and processing condition. The volume fraction of reinforcement in stir casting is up to 30% and no damage to reinforcement.

1.4. PHYSICAL CASTING

Aluminium alloy was melted in the furnace at a temperature range of 600–800°C. A stirrer is introduced in the molten metal and rotated at 200–600 rpm by an electric motor for about 10–20 min so that a vortex is created. A stirrer is introduced in the molten metal and rotated at 200–600 rpm by an electric motor for about 10–20 min so that a vortex is created.

IV. CONCLUSION

We can conclude that the addition of silicon nitride in Al7075 is helped to improve the mechanical properties of Al7075. By its ultimate strength increase into 596, yield strength increase into 525, shear strength into 352, fatigue strength 175, modulus of elasticity 76.2, shear modulus 32.7. so we can use this improved material in various disciplines.

V. ACKNOWLEDGEMENT

We would remember with grateful appreciation, the encouragement and support rendered by Dr. VINCE PAUL, Principal, Eranad Knowledge City, Manjeri. We express my deepest sense of gratitude to Mr. FAZLUDHEEN CHEMMALA, Professor and Head, Department of Mechanical Engineering and Mr. SONU T.P, Assistant Professor and project Coordinator, Department of Mechanical Engineering for their valuable advice and guidance. We would always oblige for the helping hands of all other staff members of the department and all our friends and well-wishers, who directly or indirectly contributed in this venture. Last but not least, we are indebted to God Almighty for being the guiding light throughout this project and helped us to complete the same within the stipulated time.

REFERENCES

- [1]. P. Pradeep, et.al. "Characterization of par particulate reinforced Aluminium 7075 / TiB₂ Composites" International Journal of Civil Engineering and Technology (IJCIET), Volume 8, Issue 9, September 2017
- [2]. Arunkumar D T, et.al. "Wear Behaviour and Microstructure Analysis of Al-7075 alloy reinforced with Mica and Kaolinite" IOP Conf. Series: Materials Science and Engineering
- [3]. H.G. Ranaa , V. J. Badhekab and A. Kumara. Fabrication of Al7075 / B₄C surface composite by novel Friction Stir Processing (FSP) and investigation on wear properties.
- [4]. Jamaluddin Hindi et.al. [2016], "Mechanical Characterisation of Stir Cast Aluminium7075 Matrix Reinforced ith Grey Cast Iron & Fly Ash" International Journal of Mechanical And Production Engineering, ISSN: 2320-2092. Volume- 4, Issue-6, Jun.2016 20
- [5]. Boopathiraam C et.al.[2019]prepared the specimen by using aluminium7075 reinforced with Boron carbide and Titanium carbide
- [6]. Manoj Singla, D. Deepak Dwivedi, Lakhvir Singh, Vikas Chawla "Development of Aluminium Based Silicon Carbide Particulate Métal Matrix Composite "Journal of Minerals & Materials Characterization & Engineering, Vol. 8, No.6, pp 455-467, 2009.
- [7]. Mohammed Imran, A.R. Anwar Khan Characterization of Al-7075 metal matrix composites *j m a t e r r e s t e c h n o l . 2 0 1 9 ; 8 (3) : 3 3 4 7 – 3 3 5 6*
- [8]. Habibur Rahman Md, et al. Characterization of silicon carbide reinforced aluminum matrix composites. In: Procedia engineering 10th international conference on mechanical engineering (ICME). 2013. p. 103–9, vol. 90.
- [9]. A.Baradeswaran A.Elaya Perumal, Study on mechanical and wear properties of Al 7075/Al₂O₃/graphite hybrid composites. Volume 56, January 2014, Pages 464-471
- [10]. Pardeep Sharma Satpal Sharma Dinesh Khanduja, Production and some properties of Si₃N₄ reinforced aluminium alloy composites, Journal of Asian Ceramic Societies Volume 3, Issue 3, September 2015, Pages 352-359.